



Ministry of Research and Innovation



**NATIONAL INSTITUTE OF RESEARCH AND DEVELOPMENT
FOR MECHATRONICS AND MEASUREMENT TECHNIQUE**



Results of Research, Development & Innovation in INCDMTM Bucharest

VOL. XXIII

To the attention of the:
• Quality Manager
• Marketing Manager
• Technological Transfer and
Innovation Manager

BUCHAREST 2017 ROMANIA

RESULTS OF RESEARCH, DEVELOPMENT & INNOVATION IN INCDMTM BUCHAREST

2017
VOL. XXIII



Elaborated by INCDMTM – Bucharest, by:

- Strategy, Marketing Compartment – CSM;
- Relay Centre of Technological Transfer and Consultancy – CRTTC;
- Inter-Regional Centre of Innovation and Technology Transfer Chisinau – Iasi – Bucharest – CIITT;
- Industry Links Office – OLI;
- Evaluation and Training Centre for Mechatronics – CEF „MECATRON”;
- Business and Innovation School – SAI „MINATECH”;
- Bucharest - Ilfov Regional Mechatronics Cluster – ”MECHATREC”;
- Competitiveness Strategic Pole in Mechatronics, Integronics and Adaptronics "INDMECATRON".

CONTENTS

INSTITUTE OVERVIEW.....	5
COMPARTMENT OF RESEARCH AND DEVELOPMENT «SMART MECHATRONIC MEASUREMENTS»....	9
COMPARTMENT OF RESEARCH AND DEVELOPMENT «BIOMEDICAL AND ROBOTIC MECHATRONICS»	39
COMPARTMENT OF RESEARCH AND DEVELOPMENT «MECHATRONIC MICRO AND NANOTECHNOLOGIES».....	45
COMPARTMENT OF RESEARCH AND DEVELOPMENT «STRATEGY, MARKETING».....	55
COMPARTMENT OF RESEARCH AND DEVELOPMENT «INTEGRATED MANAGEMENT»	65
INDUSTRY LINKS OFFICE • INCDMTM.....	69
RELAY CENTRE FOR TECHNOLOGICAL TRANSFER AND CONSULTANCY CRTTC – INCDMTM	71
INTER-REGIONAL CENTRE FOR INNOVATION AND TECHNOLOGY TRANSFER CHISINAU – IASI – BUCHAREST	81
NATIONAL SCIENTIFIC CLUSTER «MICRO-NANO-MECATRONICS».....	83
THE REGIONAL CLUSTER BUCHAREST-ILFOV IN THE FIELD OF MECHATRONICS, INTEGRONICS & ADAPTRONICS «MECHATREC»	85
THE STRATEGIC COMPETITIVENESS POLE IN THE FIELD OF MECHATRONICS, INTEGRONICS & ADAPTRONICS «INDMECATRON»	89
BENCHMARKING NETWORK	91
“CE–MECATRON”- CENTRE FOR PROFESSIONAL COMPETENCES IN MECHATRONICS EVALUATION / “CF–MECATRON” - CENTRE FOR PROFESSIONAL TRAINING IN MECHATRONICS.....	95
RESEARCH LABORATORIES.....	97
NGOs.....	123
SCIENTIFIC PRODUCTION 2017	126
INTERNATIONAL SCIENTIFIC PROTOCOLS.....	138

- Our Key Visual



INSTITUTE OVERVIEW

The National Institute of Research and Development in Mechatronics and Measurement Technique – INCDMTM Bucharest has as main objectives:

- basic research
- industrial research
- technological development
- elaboration of development strategies for national and European Precision Mechanics Integronics, Adaptronics, and Mechatronics industry;
- ▶ INCDMTM identifies with the following strengths:
 - intelligent measurement technique, active, automatic and computerized control;
 - equipments and integronic, adaptronic, mechatronic devices for multi-parameter integrated control;
 - non-electric physical quantities control (pressure, temperature, mass, strength, time);
 - innovative technologies;
 - tribotechnology of cutting and micro-nano-cutting processes;
 - intelligent mechatronic, integronic and adaptronic biomedical equipment;
 - robotic, microrobotic and nanorobotic systems;
 - methodologies, standards, testing and certification;
 - link with industry;
 - technology transfer;
 - development and sustainability strategies;
- ▶ INCDMTM participates in National and European RESEARCH- DEVELOPMENT - INNOVATION programs.



GENERAL MANAGER
Gh. Ion GHEORGHE
Univ. Professor PhD Eng.
Eurlng. D.h.c.

The National Institute for Research & Development in Mechatronics and Measurement Technique (INCDMTM), is a quasi - governmental organization, established by the national law for promoting R&D activities. We, at INCDMTM, are mainly responsible with fundamental and industrial researches, technological developments, technical and economic regulations, with national or limited applicability, all these regarding the field of precision mechanics and MECHATRONICS, INTEGRONICS AND INTEGRONICS. INCDMTM takes part in working out national strategies for development, giving priority to achieving the scientifically and technological objectives included in National Programs.

▶ INCDMTM activities, according to NACE: 2571; 2573; 2652; 2813; 2824; 6201; 6311; 6312; 6399; 7021; 7112; 7120; 7211; 7320; 7410; 7490; 8230; 8299; 8541; 8559; 8560; 7811; 5812; 5814; 5819; 5829; 7219; 2651; 2660; 2670; 3250; 3320 include:

- ↪ basic research and development;
- ↪ applied research activities;
- ↪ information technology;
- ↪ manufacturing activities to support specific R&D;
- ↪ studies, strategies and analyses;
- ↪ technological transfer, results capitalization and managerial consulting;
- ↪ general and special training seminars;
- ↪ publishing specialized publications and ordering information;
- ↪ activities in tertiary education;
- ↪ joining activities;
- ↪ activities abroad;
- ↪ activities additional to R&D work;

► **Sub-fields covered:**

- ↪ intelligent measurement technique;
- ↪ systems for measuring non-electrical dimensions and specific technologies for precision mechanics, mechatronics, integronics and adaptronics;
- ↪ MEMS and NEMS;
- ↪ instruments for laboratories and research, special biomedical and environment equipment;
- ↪ quality engineering, assurance and certifying;
- ↪ strategy development, marketing and technological transfer.

► **Our main achievements grouped according to the aforementioned activity sub-fields:**

• **Methods, technologies, measuring and control instruments for assessing quality characteristics through different proceedings, according to measuring techniques:**

a) **dimensional control integrated with manufacturing process - in process control, automated and numerical control for:**

- automotive industry;
- bearings industry;
- injection pumps industry;

b) **out of process dimensional control for:**

- FMCG industries;
- motors industry;

c) **control technologies and measuring equipment using laser interferometers, inductive and photoelectric sensors and transducers;**

d) **MECHATRONIC, INTEGRONIC AND ADAPTRONIC equipment and installations for multidimensional control, using a high degree of automation and numerical data processing;**

• **Concepts and methods for improving competitiveness, reliability and capability in industrial processes; new materials, along with appropriate technologies for using them in mechatronics, integronics and adaptronics:**

- a) **control of non-electrical sizes - pressure, temperature, mass, force, time;**
- b) **technologies, carbide tools, diamond tools, posts for tools;**

- c) equipment for specific testing and investigation methods and procedures;
- d) adapting and applying new technologies and micro-nano-technologies for rationalization and optimization in industrial processes, for cutting costs and consumption, and raising productivity;
- e) building and developing seismic stations;
- f) surveillance active/passive mechatronic, integronic and adaptronic systems for normal wear and catastrophic tools;
- g) tribotechnological characterization of cutting and micro-cutting processes (grinding, turning, super-equaling) with tools with the active part made up of hard materials
- **Methods, procedures and instruments for evaluation of trends, prognoses and strategies for the industry of precision mechanics, mechatronics, integronics and adaptronics:**
 - a) strategies for restructuring and development the precision mechanics, integronic, adaptronic, and mechatronic industry;
 - b) strategies for approaching and integrating the precision mechanics, integronic, adaptronic, and mechatronic industry to EU market.
- **Technological transfer, result capitalization and consulting, offered to manufacturing companies and consumers in the industry:**
 - a) control technology for gears parameters;
 - b) control technology for the main parts of the motors with internal combustion;
 - c) manufacturing technologies for blanks from sintered metal carbides and diamonds;
 - d) equipment for gears profile and lead.

► **Other data:**

- Year of establishing: 1971
- Number of employees: 135 (22 PhD Engs, 6 PhD students)
- Collaborators: over 40 R&D Romanian institutions operating in different fields of knowledge and industry; polytechnic and specialized universities in Brasov, Cluj, Bucharest, Timisoara, etc.
- Endowment: suitable to accomplished activities
- INCDMTM is registered in the Registry of Commerce
 - ✓ Member of:
 - Romanian Chamber of Commerce and Industry, Bucharest
 - General Engineers' Association in Romania
 - Romanian Society of Mechatronics
 - Association of the Romanian Patronage in Precision Mechanics, Optics and Mechatronics Industry
 - Professional Association of Precision Mechanics and Optics from Romania
 - CONPIROM
 - ✓ Tutelary Forum:
 - Ministry of Research and Innovation;

In 2013, INCDMTM has been the subject of an international evaluation process (between September 12-13), and received the highest rank A+.

CODIFICATION OF PRODUCTS ACCORDING TO NACE **ARRANGEMENT OF ACTIVITIES IN THE NATIONAL ECONOMY**

- ✓ **Metallic construction and metal products industry:** **NACE 257**

- ✓ **Cutting tools and products:** **NACE 2571**

- ✓ **Hand Tools:** **NACE 2573**

- ✓ **Machinery and medical instruments, precision, optical and watch making:** **NACE 265;266;266;
267;325;3320**

- ✓ **Machinery and medical instruments:** **NACE 2660; 3250**

- ✓ **Machinery and tools of measurement, verification and control:** **NACE 2651**

- ✓ **Measurement, regulating and controlling equipments:** **NACE 8320**

- ✓ **Optical and photographic devices:** **NACE 2670**

- ✓ **Clocks and clock mechanisms industry:** **NACE 2652**



**COMPARTMENT OF
RESEARCH AND
DEVELOPMENT
«SMART MECHATRONIC
MEASUREMENTS»**

THE DIVISION OF RESEARCH AND DEVELOPMENT FOR SMART MECHATRONIC MEASUREMENT offers Professional solutions and services of excellence

The INCDMTM proposal – through the DIVISION OF RESEARCH AND DEVELOPMENT FOR SMART MECHATRONIC MEASUREMENT-comprises a wide palette of computer-aided intelligent complex measuring and integrated control equipments.

The DIVISION OF RESEARCH AND DEVELOPMENT FOR SMART MECHATRONIC MEASUREMENT, oriented on producing and developing mechatronic measuring means and techniques is prepared to help clients efficiently with the view to obtaining a quality production and to transform production in a intelligent production processes.

The DIVISION OF RESEARCH AND DEVELOPMENT FOR SMART MECHATRONIC MEASUREMENT also offers service; this facility includes:

- Putting into operation;
- Training;
- Warranty;
- Service;
- Maintenance and product remedy contracts.

NACE 265;267;332

- ▶ **Intelligent Measuring, Testing and Control Devices and Tools;** ◀ **NACE 2651** ▶

- ▶ **Mechatronic, Integronic and Adaptronic Measuring, Arrangement and Control Devices for industrial processes;** ◀ **NACE 3320** ▶

- ▶ **Optical and Photographical Devices;** ◀ **NACE 2670** ▶

- ▶ **Watches and timing mechanisms** ◀ **NACE 2652** ▶

MECHATRONIC EQUIPMENT FOR MULTIPARAMETRIC MEASUREMENT OF THE INNER AND OUTER RINGS OF BALL AND ROLLER BEARINGS

Developed under Partnerships in Priority Areas Programme – PN II, supported by MEN-UEFISCDI in project PN II-PT-PCCA-2013-4-1671

Achieved in partnership with: University Politehnica of Bucharest, National Institute of Research – Development in Informatics – ICI, SC COMIS SRL

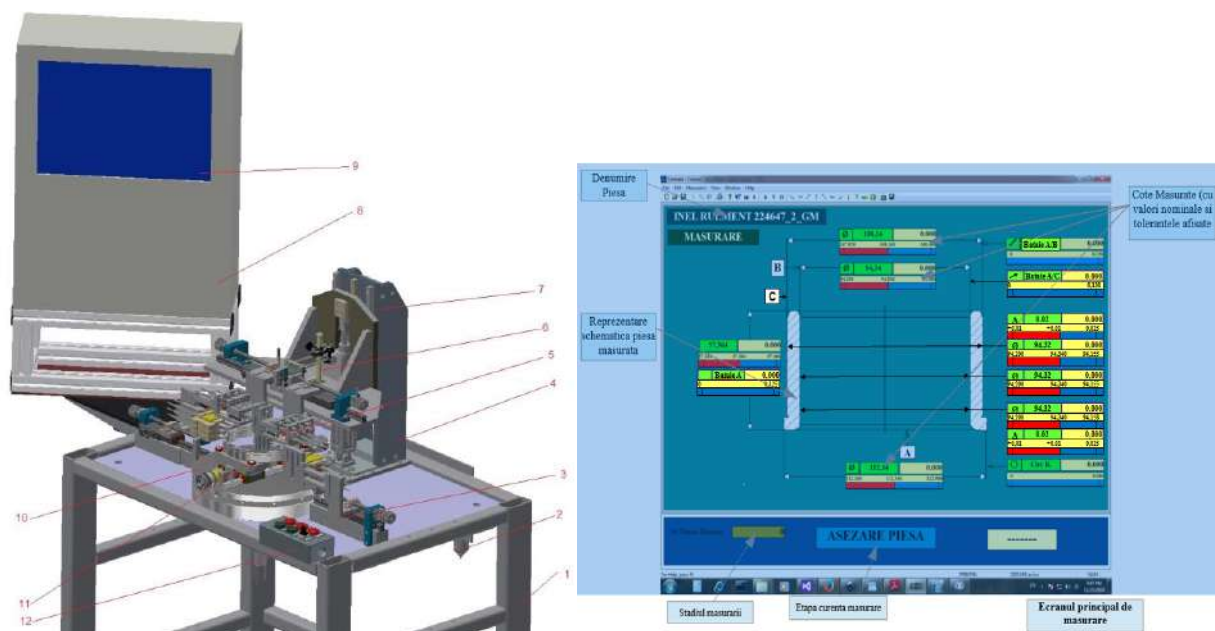

1. Working table;
2. Air preparing group;
3. Outer surfaces measurement system;
4. Vertical column;
5. Inner surfaces measurement system;
6. Axial measurement system;

- Measurement scheme
7. Vertical sledge;
 8. Data processing and acquisition unit
 9. Display
 10. Rotating table
 11. Part centering rollers
 12. Console for manual controls
 - T1...T18 – measurement transducers

Figure 1 Equipment for multi-parametric measurement of bearing rings

The equipment has a modular hardware and software structure for increasing functional flexibility. Using modular electronic configurations for measuring and decision on measured parts quality, allows the achievement of complex calculation and correlation functions. The ring can be centered to the axis of rotary table, on the inner or outer diameter, with four rollers.

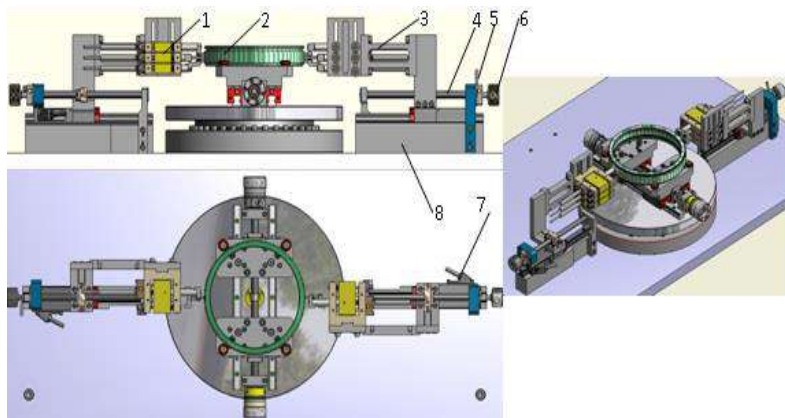

1. Left outer surfaces measurement system;
2. Measured bearing ring;
3. Right outer surfaces measurement system;
4. Driving screw;
5. Locking mechanism
6. Hand wheel
7. Linear guidance with measurement unit
8. Supports for linear guidance

Figure 2 Ring centering and outer surfaces measurement subassembly

The equipment allows simultaneously measurement of inner and outer diameters of the bearing rings in maximum three horizontal planes. The distance from the contact surface of the rings from the first measuring section must be greater than the height of the centering rollers. The minimum distance between two consecutive measuring sections must be at least 5 mm, thereby resulting from constructive dimensions of the probes.

The product is still under construction.

TECHNICAL FEATURES:

- Hardware and software modular construction
- Characteristics of measured parts:
 - Shape: all parts can be centered on the outer or inner diameter, based on a flat surface and measurable characteristics are specific for bodies of revolution;
 - Material: all measured parts are made of metallic materials, specific for bearing rings manufacturing;
 - Technical quality conditions:
 - Surfaces quality: $R_a = 0,8 \dots 6,3$
 - Sizes: inner diameters: 48...190 mm; outer diameters: 50...200 mm;
 - Heights: max. 50 mm;
 - Dimensional and geometric accuracy: 0.05 ... 0,5 mm;
 - Repeatability: 0,005 mm;
 - Accuracy: 0,01 mm.

APPLICABILITY: Bearing industry

BENEFICIARY:

- SC COMIS SRL
- Potential beneficiary can be any company acting in the bearing industry

FURTHER INFORMATION:

PhD.eng. Daniela CIOBOATA, e-mail: ciobatadoina@yahoo.com

MECHATRONIC SYSTEM FOR MEASURING THE ROLLING ROLING PROFILE OF THE RAILWAY WHEELS IN ORDER TO OPTIMIZE THE SHEAPING/ RESHAPING ON CNC MACHINE TOOLS

Developed under Partnerships in Priority Areas Programme – PN II, supported by MEN-UEFISCDI in project PN II-PT-PCCA-2013-4-1681

Achieved in partnership with: University Politehnica of Bucharest and SC Uzina de Vagoane Aiud.

PRODUCT OVERVIEW:

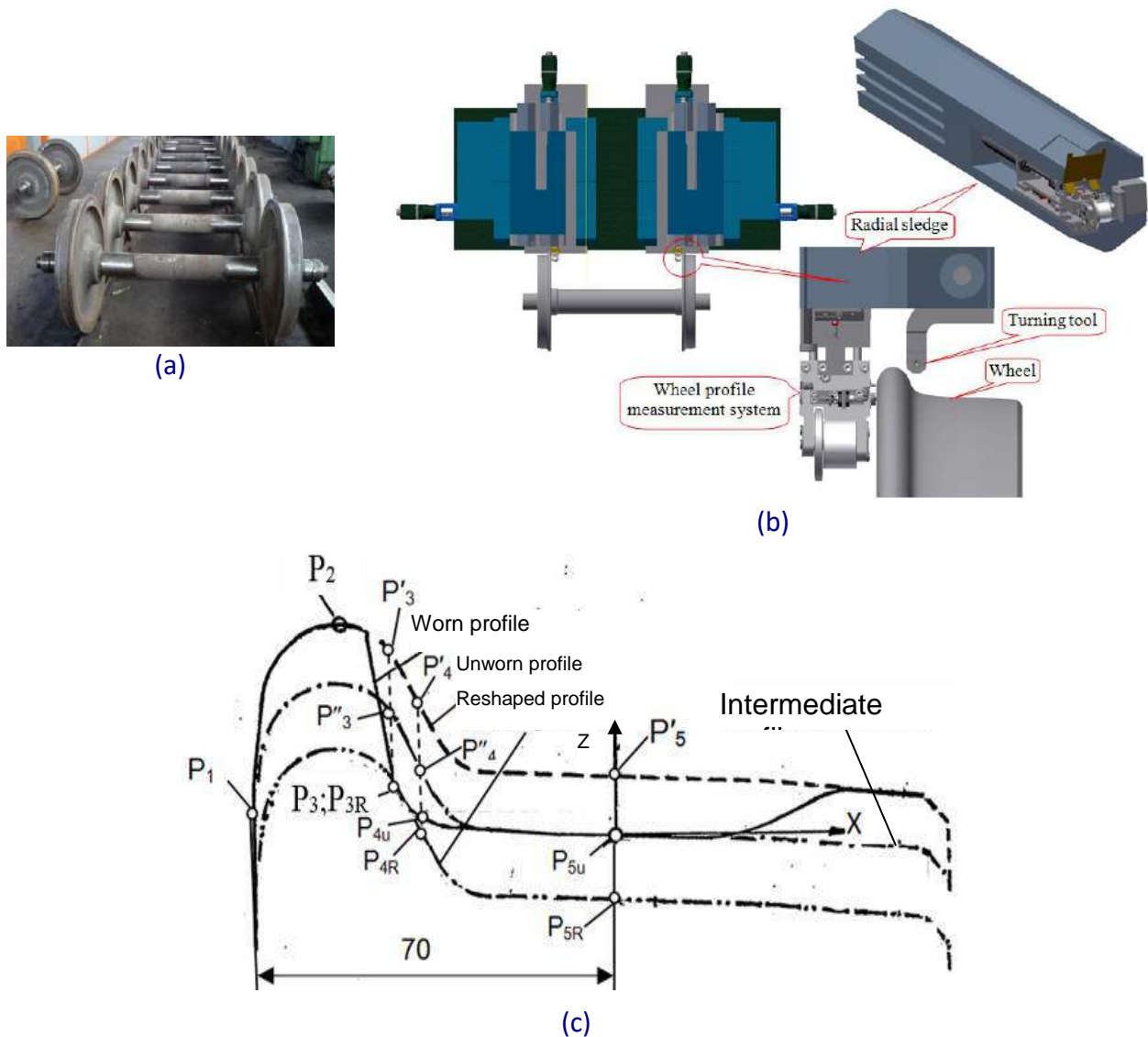

Figure 1.a. Wheelsets; b. Profile measurement system; c. Measurement points

One measurement system are mounted on each radial sledge of the lathe in a special milling space, parallel with tool holder. The measurements are performed on radial and axial directions by probing the characteristic points of profiles. by palpating the minutia of the profile.

The Measurements systems moving for probing the characteristic points is performed by numerically controlled radial and longitudinal sledges of the shaping/reshaping lathe.

Deviations from nominal positions of the characteristic points of the profile are measured with incremental encoders (measurement range ± 10 mm) for radial direction and with inductive sensors (with measuring range: ± 2 mm) for axial direction. During turning, the measuring systems are retracted into the slots of the radial sledges and are protected by a cover. For measuring, they are pushed out of the radial sledge slots by pneumatic cylinders.

The product is still under construction.

TECHNICAL FEATURES:

- Pneumatic push in or push out of the measurement systems
- Measuring range on radial direction: 0...10 mm
- Measuring range on axial direction: 0...5 mm
- Accuracy: ± 50 μ m
- Repeatability: ± 30 μ m

APPLICABILITY: Rolling stock industry

BENEFICIARY:

- SC Uzina de Vagoane Aiud
- Potential beneficiary can be any depot or centre acting in rolling stock repairing or maintenance.

FURTHER INFORMATION:

PhD.eng. Daniela CIOBOATA, e-mail: cioboadoina@yahoo.com

INNOVATIVE MECHATRONIC SYSTEM FOR THE CONTROL OF BEARING RINGS PROCESSED WITH CNC MACHINES

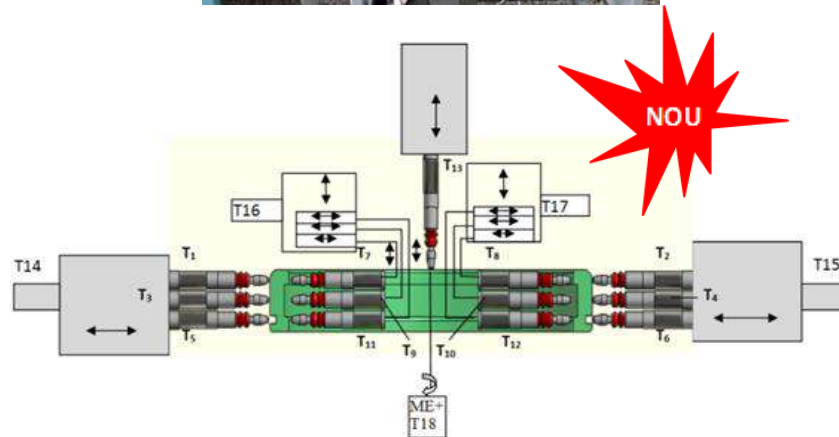

Product Overview:

The system has a modular hardware and software construction for controlling parts with revolution surfaces that can be centered on their inner or outer diameters, made of metallic materials specific to the manufacturing of bearing rings.

Technical Features:

- Surface quality: $R_a = 0.8 \dots 6.3 \mu\text{m}$
- Dimensions: inner diameters: 48...190 mm; outer diameters: 50...200 mm;
- Heights: max. 50 mm;
- Dimensional precision and of shape deviations: 0.05 ... 0,5 mm;
- Repeatability: 0.005 mm;
- Measurement accuracy: 0.01 mm.

Applicability: Bearing industry.

Technology Transfer: The product can be used by SMEs that manufacture bearings.

Beneficiary: SC COMIS SRL Valenii de Munte, Jud. Prahova.

Further Information: PhD.Eng. Daniela CIOBOATĂ; e-mail: ciboatadoina@yahoo.com

INTELLIGENT UNIT FOR TIGHTNESS CONTROL FOR H5-2nd Generation pre-machined BASEPLATE ASSAMBLEY CYLINDER BLOCK (SEMELLE)



Product overview

The testing unit is a complex, mono-block construction use in checking tightness of the pieces type Baseplate Assambley Cylinder Block (Semelle). The unit is equipped with a swivel plate which allows checking a piece while uploading or downloadin the other piece.

The unit is equipped with two rows of safety barriers, primarily barriers disables the rotation of the piece, allowing replacement piece checked the loading station, and secondly, disables any movement of the machine when entering the working area an object or a person.

Working cycle is automatic.

All the moving subassemblies are operated by pneumatic cylinders assisted by a lot of proximities sensors. The piece is tightening on all sides, including the tilt one.

The ATEQ-cell is provided with 2 circuits and realizes the measurement cycle after the fixation and tightening the piece.

Main features techniques:

- Supply/ work pressure: min. 5 bar/6 bar min
- control pressure: 1 bar for both circuits (aer circuit, oil circuit);
- type of measurement: the pressure difference;
- the measuring mode: în cm³/min și Pa;
- the level of air leakage: 25 cm³ / min for the low pressure circuit (air circuit), 3.6 cm³ / min for the high pressure circuit (oil circuit);
- cycle time: 40s/piece;
- electricity: 220 V c.a.; 50 Hz.
- accepted air loss: 3,6 cm³ / min and 7,2 cm³/min for impregnable piece
- PLC: Siemens
- operating panel: OP77
- operating system: Win CC for OP77
- type control: 100% (piece by piece)
- marking: E for good piece and H for impregnable piece

BENEFICIARY: S.C. Automobile Dacia Group Renault S.A. Mioveni, Argeș, Romania.

FURTHER INFORMATION: Mihai Hacman: laborator_tm1@yahoo.com

SMART MECHATRONIC CONTROL SYSTEM FOR IN VACUUM TIGHTNESS CONTROL OF MACHINED R145 CARTERS



Product overview:

The mono-block construction is equipped with a turntable (driven by a rotary electric motor) which allows simultaneous checking of two conjugated parts forming the R145 crankcase:

- Verification is done in vacuum at -0.5 bar.
- it has two workstations, one for loading and one for leakage checking.
- it will be served by a robot which will be communicating with it to allow loading, unloading, and classification of the parts

All moving parts are driven by pneumatic cylinders assisted by proximity sensors.

Technical Features:

- Power supply: 400 V / 50 Hz / 10 KVA
- Supply pressure: 6 bar;
- Working pressure: 5.5 bar;
- Test pressure: -0.5 bar;
- Admissible air loss: 25 cm³ / min;
- Cycle time: ~ 40 sec / piece.
- Air-to-air tightness test: ATEQ F510 cell;
- Automatic: Siemens;
- Operator panel: AP700;
- Operating system: WinCC;
- Control type: 100% (conjugated parts);
- Marking: "good part" - E
- Tag identification "datamatrix": video camera



BENEFICIARY: SC Automobile DACIA Group Renault SA Mioveni

SMART MECHATRONIC CONTROL SYSTEM OF CYLINDER HEAD COVER



Product overview:

The installation is a complex mono-block construction.

All moving parts are driven by pneumatic cylinders assisted by proximity sensors. The piece is sealed on all sides. The differential measuring cell performs the measurement cycle after the part has been fastened and sealed.



Technical Features:

- Power supply: 220 VDC / 50 Hz;
- Supply pressure: min. 6 bar;
- Working pressure: 5 bar;
- Test pressure: 1 bar;
- Permissible air loss: 25 cm³;
- Air-to-air tightness test: differential measuring cell;
- Programmable controller: Siemens S7-315 2DP;
- Operator panel: OP77;
- Operating system: WinCC.

FUTURE BENEFICIARY:: SC Automobile DACIA Group Renault SA Mioveni

EQUIPMENT FOR VERIFYING GEAR CASING TYPE TL4-xx

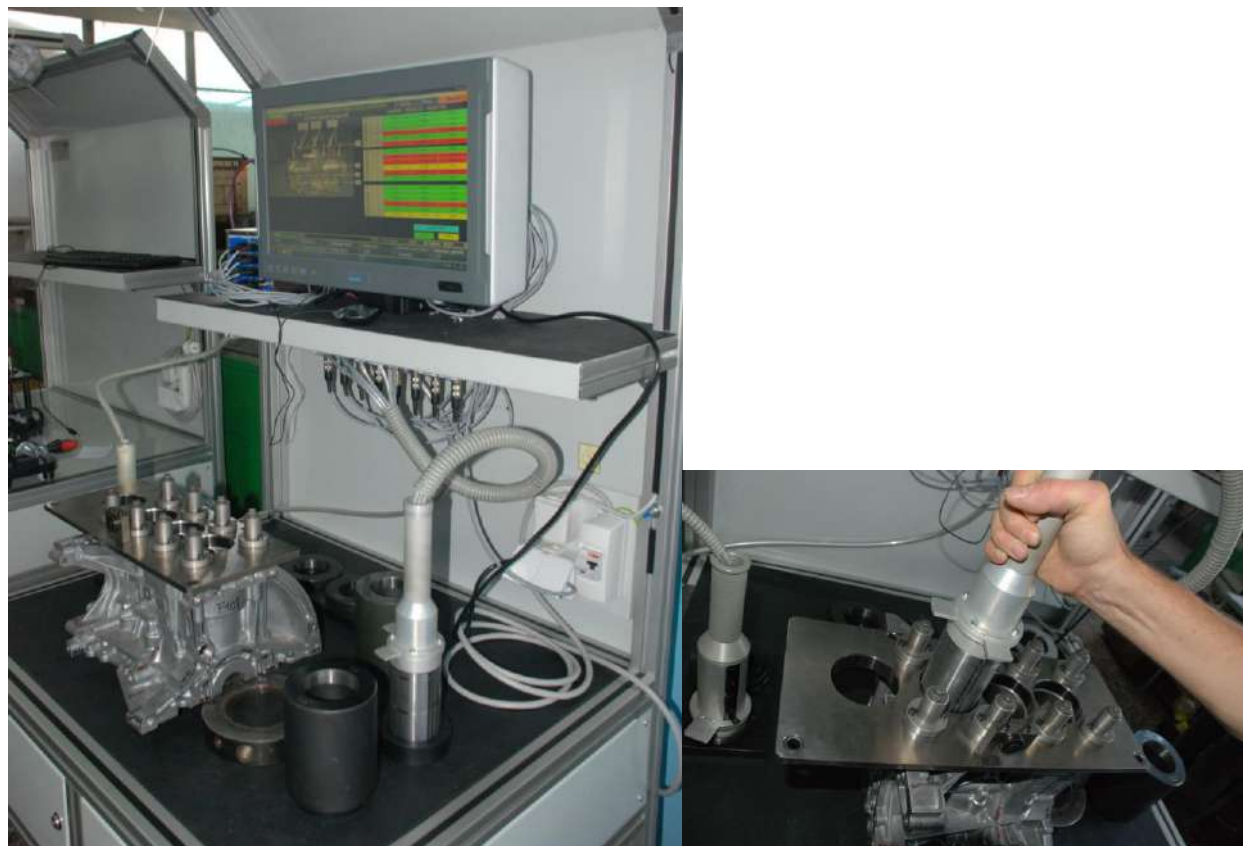

The equipment verify diameters and bores for Gear Casing type H4-XX:

- limitative control gauges;
- pneumatic plug with standards (acuracy: 0,001mm);
- central measurement SIRIUS with accesories;
- accesORIZED control table with FESTO air preparation group

BENEFICIARY: S.C. Automobile Dacia Group Renault S.A. Mioveni, Argeş, Romania.

FURTHER INFORMATION: Mihai Hacman: laborator_tm1@yahoo.com

CONTROL DEVICE FOR VERIFYING CRANKSHAFT TYPE K7-H4

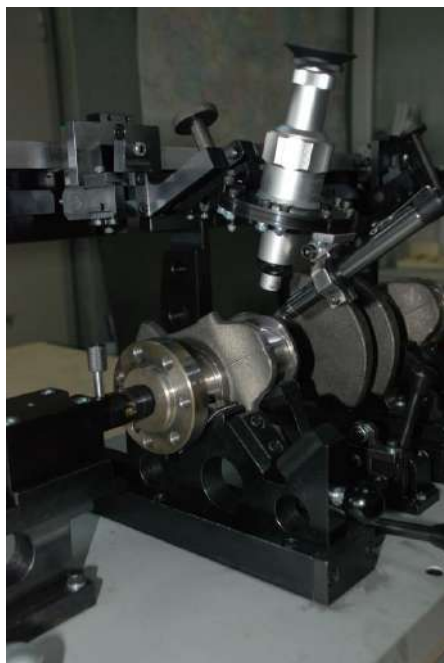

The device is designed for the control of the chamfers dimensions for lubrication holes (crankpins and bearings)

Verify tyoe: optical with two, 10x magnifying

Stroke value: 0,1 mm

BENEFICIARY: S.C. Automobile Dacia Group Renault S.A. Mioveni, Argeş, Romania.

FURTHER INFORMATION: Mihai Hacman: laborator_tm1@yahoo.com

CONTROL DEVICES FOR CONNECTING ROD LASER-CUT H4-XX



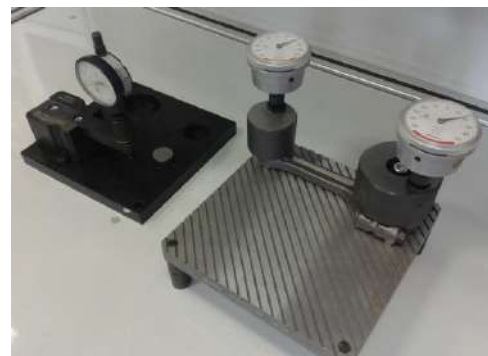

Equipment, devices and attributes for control „connecting rod with laser-cut”:

- diameters;
- cylindricity “twist” and “bend”;
- perpendicularity
- distance between the axes of rod eyelets;
- axis position for rod eyelets;
- hole and chamfer depths;
- verifying threads and thread depths; ;
- thickness
- angle dimensions;
- axial and radial displacements between eyelets
- bush position
- checking flatness laser rupture zone
- sides parallelism;
- sides flatness;
- middle plan symmetry
- and many others

MACHINED BR10 CYLINDER CARTER CONTROL INSTALLATION



The unit verifies the diameters and ovalities for the casing of the cylinder:

- pneumatic control plug with one section on two direction and three levels, with master setting rings;
- pneumatic control plug with three sections on two direction, with master setting rings;
- PLC: Siemens;
- pneumatics: FESTO
- accuracy: 0,001 mm.

TRANSFER CAPACITY DEVELOPMENT AND COMMERCIALIZATION OF THE RESULTS OF RESEARCH FROM THE INSTITUTES AND CENTRES for APPLIED RESEARCH IN ROMANIA - THE IMPLEMENTATION OF A PILOT MODEL FOR SPECIALTY DEPARTMENTS

The overall objective of the ANCSI Sectoral Plan:

"Infrastructure development R & D"

Specific objective of the Sectoral Plan:

"Improving performance profile the activity of the R & D "

Project leader: Bucharest Polytechnic University/ UPB

Partners: 1 INCDMTM; 2 CER, 3 UPB; 4 AROTT; 5 INCDTP; 6 CIT IRECSON; 7ICPE CA

The specific objectives are:

- Analysis of the current general situation of specialized technology transfer infrastructure and capitalization in the EU and comparing it with the current general situation similar infrastructure in Romania;
- identification of specific country and region to be taken into account when defining the pilot model and its mission to support competitiveness and regional communities in the geographic areas to which it belongs;
- analysis and selection of economic sectors and scientific fields that underpin the implementation of technology transfer and capitalization the functions within the model pilot;
- pilot model design and implementation plan;
- verifying and demonstrating Exhibitionness and sustainability of critical elements of the proposed model by implementing the selected institutions;
- developing a feasibility study to underpin subsequent implementations

These operational objectives can be detailed as following measurable objectives (MO):

OM1.1: Identifying country-specific and general elements characteristic for specialized structures for TT and capitalization;

OM1.2: Identification of an institutional model with structural features and optimal performance;

OM1.3: SWOT analysis of the identified elements;

OM1.4: Report on institutional models and best practices identified and the specific elements applicable to our country; Introducing the notion of expert commercialization of research results

OM2.1: Analysis and selection of economic sectors and scientific fields that underpin the implementation of pilot model;

OM2.2: Pilot model development;

OM2.3: Develop a plan for implementing the pilot model; Creating a system of specialized staff training in the field of technology and knowledge transfer and commercialization of the research.

Development model of organization of the national centers of knowledge and technology transfer and commercialization of the results.

OM2.4: Selecting an applied research institute or center for pilot application of the model;

- OM2.5: Pre-feasibility study for implementation of pilot model;
- OM2.6: Report on pilot model and implementation plan in applied research institute or the center selected;
- OM3.1: Develop a plan to pilot testing and demonstration model and implementation plan;
- OM3.2: Implementing the plan verification, demonstration and implementation of pilot model;
- OM3.3: Comparative study on the feasibility study provisions in relation to the results of the verifications and demonstrations carried out;
- OM4.1: Identification of possible malfunctions of the previous phases and drawing also recommendations for corrective action;
- OM4.2: Adjusting pilot model based on the recommendations resulting from previous inspections and practical demonstrations;
- OM4.3: Develop a feasibility study to underpin the implementation of the pilot model;
- OM4.4: Organizing debates institutes, research centers and universities applied for the presentation of the project results;
- OM4.5 Draft Memorandum of Understanding between MEN, applied research institutes and universities concerning the undertakings of and responsibilities to ensure competitiveness and sustainability of TT and capitalization infrastructures within them. Making recommendations for rules and regulations concerning TT

Technology Transfer (TT), a priority of scientific research

The complexity of the problem, also explains the diversity that this happens, the actors involved in the organized transfer, missions and tasks of the bodies involved. Consensus of the specialists emerges that Technology Transfer (TT) is the final part of a research carried – the part conferring value to the efforts involved - and that must be treated unitary as form and substance: Innovation-Technology Transfer. A first remark that emerges from analysis of the experience of companies, is about the responsibility of research funding bodies – public or in favor of private companies - namely not only responsibility in the selection and conducting of research, but especially its completion and commercial transfer to a beneficiary, which the private companies research makes it better, the company being directly interested in spending research funding with maximum effect.

It is the case of Romania or even of some European projects that pays great attention to drawing the research agenda, for evaluation and funding, but less involved in the final stages of research that are related to transfer. Maybe insufficient personnel hired in the NASR (National Authority for Scientific Research) for this activity are also one of the reasons that make the Technology Transfer (TT) not have the weight that it should have.

Concerned about how the funds for research are used, states are developing their policies to accelerate technology transfer, developing models that more closely resemble the philosophy of such a complex process that depends on many factors, its accelerating and finding the most appropriate ways of trading scientific outcome.

Is more and more obvious that the existence of an effective technology transfer in Romania will depend on how the law enforcement bodies will respond to the challenges facing those interested in the transfer. The competitiveness of an economy depends on how this technology

transfer is made, from the result of public scientific research to the practical application in a company, the synergy of the activities conducted by the two partners. The competences in labor, competitiveness of R&D, development of innovation and entrepreneurship professional centers, technical culture that contributes to change and elimination of resistance to novelty, are essential activities in developing a successful TT and competitiveness of an economy. Factors that influence the competitiveness of an economy.



Figure 1: The competitiveness of an economy depends on many factors

In Figure 1 were synthetically presented the factors with impact on the competitiveness of an economy, scientific research through a series of formal actions (on contractual basis) or informal (contacts between members of the academic community and the industrial environment) may have a important role in increasing the company's scientific competitiveness and development of joint research programs, TT activities, personnel training and training, creation of centers of innovation and entrepreneurship, synergy of activities, nurturing a sense of acceptance of new and eliminating renewal resistance.



Figure 2: Actions developed by research institutes on Technology Transfer line, for companies

Activities mentioned in Figure 2 that lead by applying them to technical exploitation and commercialization of some results, are based on actions developed by the Institutes in R&D projects, developing new business, joint venture, startups or spinoffs, sales of licenses and technology transfer of some results, cooperation and assistance to the technical, economic or organizational issues, formation of alliances and clusters to increase the efficiency of technology transfer.

Cooperation between scientific research units wishing to transfer a solution solved or required for solving by a company is much stronger and more effective the closer involvement of research is, measured by the number of shares to the company and its effectiveness is validated by results. Figure 2 shows the whole spectrum of actions that a research institute or university can develop in favor of companies, the actions to be undertaken resulting from agreements between the research unit and company.

In developing a technology transfer project that aims to commercialize the results obtained in industrial research by innovation were summarized in Figure 3, best practices encountered in literature, useful in defining a Romanian model of technology transfer.

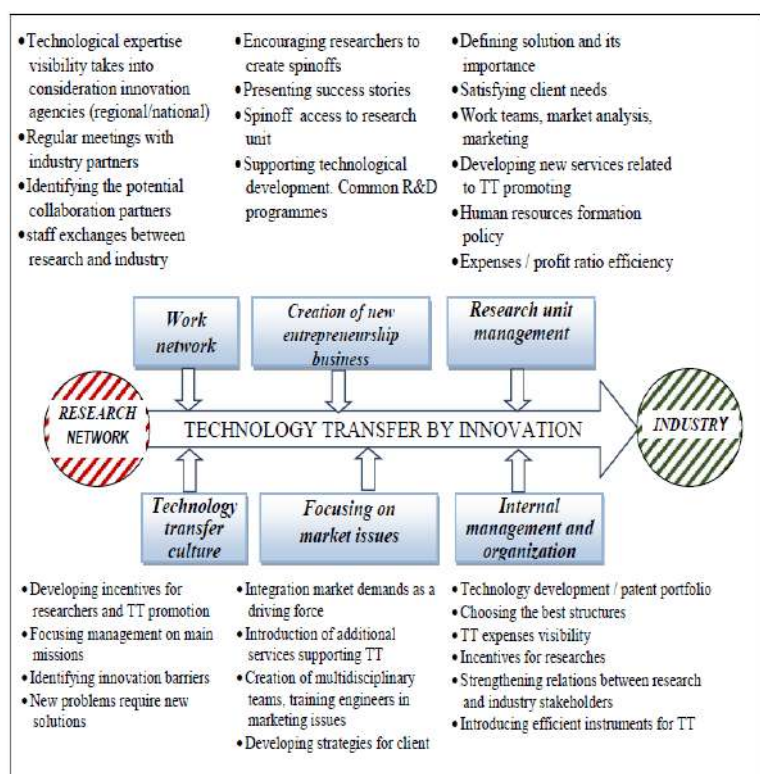

Figure 3. A synthesis of actions to support technology transfer, best practices in other countries

The project has proposed that starting from the analysis of how countries in the world manage technology transfer and from the existence of models with results validated by existence of best practices, to develop a TT model with elements applicable in Romania.

Outside TT formally practiced over the years Informal Transfer is strengthening, based on ceding knowledge gained at academic institutions and researchers through direct contact with the industry (joint research programs, industry personnel, access to laboratories, technical assistance).

Technology Transfer is not a spontaneous process, it is part of a country development strategy, and it must be organized and supported financially, by legislation, is a process that costs, which requires increased responsibility of a country. The project concludes with recommendations to be taken into account when a TT project is developed.

Responsible for the project: dr.ing. Diana Mura Badea, Tel: +40740113589; E-mail: dianamura@yahoo.com

WATER NETWORK SENSORS FOR WIDESPREAD USE / WIDSENS

Project Acronym: WIDSENS

Project Title: Water Network Sensors for Widespread Use

Call identifier: FP7-SME-2013 Activity 2.1: Research for SMEs

Grant agreement no.: 605802

The consortium is composed of:

1. WELLNESS TELECOM SME Spain/ CO
2. T.E. LABORATORIES LIMITED SME Ireland
3. HYDRELIS SME France
4. AGENCIA ESTATAL CONSEJO SUPERIOR DE INVESTIGACIONES CIENTIFICAS CSIC RTD Spain
5. NATIONAL INSTITUTE OF RESEARCH DEVELOPMENT FOR MECHATRONICS AND MEASUREMENT TECHNIQUE RTD Romania

Generalities

In recent years the water sector has become a widespread user of Information and Communication Technologies (ICT) for planning and operation. These technologies are needed not only to comply with stricter regulations and safety measures, rising quality standards and challenging social and environmental demands but also to face serious problems of aging infrastructure, which includes leakage and quality issues related to the water supply network.

On the other hand, the supply of drinking water that is healthy, clean and palatable is a fundamental requirement of the European drinking water directive. World Health Organization (WHO) guidelines for drinking water¹ are used as a basis for the standards in the Drinking Water Directive (DWD)². There are many examples of drinking water entering the distribution system which is not compliant with European legislation and also poses a significant health risk to the community. In a worldwide context there are also examples of drinking water entering the distribution system with minimal or no quality checks against this standard.

As a result, there has been a growing demand for Real Time (RT) water management solutions, however, these technologies are still far from mature and they do not provide a real solution to the water sector needs for analysis, control and data measurement. Current water probes/sensors have traditional inconveniences that limit their usage for water quality control in supply networks:

- Unsustainable energy consumption
- Fragility
- Manual calibration at laboratory
- High maintenance needs
- Electrolyte leakage (for reference electrode)
- Lack of accuracy

These technical inconveniences have made sensor grids very difficult to implement but also the total cost of ownership (TCO) (equipment + installation + maintenance) makes economically prohibitive a widespread use. Besides, the key ICT challenges for the water sector relate to the

economics of providing arrays of low cost sensors that could be deployed in remote locations, to data communications from these remote locations and to the powering of such sensors and communications.

The main objective of the project WIDESENS/ FP7 SME is to develop a multiparametric analytical probe based on semiconductor technology sensors that can be directly inserted in the pipelines. This probe will continuously monitor a number of the basic key parameters detailed within the European Drinking Water Directive 98/83/CE2. The specific features of this probe are:

- Robust probe fabrication: Solid built with electronics and mechanics confined into a water-resistant case.
- Low cost: Low cost (purchase, installation & maintenance) to allow wider deployments for a better resolution. We aim at a recommended retail price of 1000-2000€.
- Ultra low energy consumption: It is targeted that the system could run on a single battery for over a year, allowed by the use of the latest sensor semiconductor technology together with efficient electro-mechanics and low energy wireless communications.
- Pressure resistance: The exposed parts become almost unbreakable thanks to the incomparable toughness of silicon components. This means that sensors are free of fragile membranes or glass.
- Free of electrolyte: Research will be done on the field of reference electrodes with a solid state reference solution and free of leaking.
- Temperature and drift compensation for long-term monitoring: A novel compensation technique for counteracting simultaneous change of temperature and drift will be applied. This will involve the design of the sensory system incorporating hardware and software co-design for enhancing the performance stability of the sensors.
- An innovative self-calibration mechanism will be incorporated in the probe to allow sensors being calibrated in situ.
- An innovative cleaning system will be designed to avoid the formation of biofilms, increasing the sensor lifetime.
- Pressure sensor will be included to enable leak detection in pipes.
- Innovative interface software for decision support in the water management.

RESEARCH AND DEVELOPMENT OBJECTIVES:

1. DEVELOPMENT OF INNOVATIVE SENSORS FOR WATER MONITORING

Electrochemical solid state sensors based on semiconductor devices are devised as a feasible solution towards a widespread deployment of sensors. They have the advantages of robustness, reproducibility of fabrication, miniaturization, low power consumption, rapid response, highly appreciated for the proposed application. The water quality sensors types and related parameters proposed in this project are: Ion Sensitive Field Effect Transistor (ISFET) for pH detection, Interdigitated electrodes (IDEs) for conductivity and biofouling determination, Pt electrodes for ORP (redox potential) detection and gold amperometric microelectrodes for chlorine detection. The chips will be fabricated and encapsulated by the group of IMB-CSIC . Although these parameters have been chosen in a first attempt of the project, these sensors could be extended to other parameters already studied by this group (i.e. ions, heavy metals).

There are still some limitations of chemical sensors that WIDESENS will address like temperature sensitivity, drift, and the need of a stable reference electrode:

- Temperature effect, due to the semiconductor nature of the ISFETs and the temperature

dependence of conductivity for the IDEs, it is mandatory to correct the signal variation due to temperature. This can be carried out by software, having a temperature probe within the system and applying algorithms for calibration data correction. Usually ISFET-based sensors have a temperature coefficient that is constant under a reasonable range of conductivity. Therefore this coefficient can be applied in the calibration algorithm.

Measurable outputs: Along the characterization of sensors carried out in WP3 temperature coefficients will be established within the defined pH range in order to build an algorithm able to perform automatically the temperature correction.

· Drift or signal change with time, that affects mainly the ISFET sensor. There are several aspects that have to be considered: 1) the drift is an intrinsically phenomena of the ISFET due to the dielectric material used to define the sensing area⁴. This behavior will always exist; 2) If its value is constant it can be corrected by software, 3) the drift of ISFETs in a pH 7 solution during a period of four months is around 0.01 mV/h, for ISFETs with Tantalum Oxide as sensing material and 0.04 mV/h for silicon nitride ISFETs. That means a pH variation between 0.0002 and 0.0007 pH units/h. This pH variation is insignificant if we accept a precision of 5.0%.

Therefore in this project we will study the drift effect under the conditions of measurement, and we will develop an algorithm for correcting the drift.

Measurable outputs: Drift will be characterized as a function of different parameters: pH and conductivity in WP3 during testing of sensors. According to obtained results, an algorithm will be developed and incorporated in the control and interface software

· Stable reference electrode. A stable reference electrode is required for measuring with electrochemical sensors. In the case of ISFETs a new approach using differential measurement with a reference ISFET (REFET) and a pH ISFET will be used. For the REFET a microfluidic structure will be developed to maintain the sensitive part of the ISFET with a constant pH. This device is already developed in the IMB-CSIC laboratories⁵. It is based on the utilization of compatible PDMS (a polymeric material) technology with the encapsulation technology for sensors. PDMS microfluidic structures allow creating micro channels on top of the sensor that can be used as solutions reservoirs.

This approach will be also used to fabricate a miniaturized Ag/AgCl reference electrode for the amperometric and ORP devices. These reference electrodes need an internal reference solution, usually KCl, and an ionic bridge to contact with the external solution.

One of the main problems of these electrodes applied in-situ is the reduced long-term stability due to the internal reference solution leakage to the medium. Approaches like solid state internal reference solutions – called leak free electrodes- have been proposed everywhere. These are based on gel-like electrolytes or polymeric materials that contain the ionic salt, thus reducing the leaking of the salt or ionic junctions who are not porous but highly conductive (10 K Ω). These electrodes are basically for laboratory purposes although some other solutions like melt electrolyte salts have been recently proposed.

When miniaturization of the reference electrode is required, some attempts have been addressed to integrate the ref. electrode within the microelectrode substrate. But this approach is only effective for disposable sensors due to the short lifetime of these electrodes. In this project we will combine the miniaturization technology of a Ag/AgCl electrodes⁸ and the PDMS technology to build reference electrodes for the developed sensors.

Response characteristics of WIDSENS sensors

Parameter Concentration range Limit of detection (LOD) Precision

pH 4,5-10,5 na < ±5%

Conductivity 0- 5.000 μS/cm 50 μS/cm at 20°C <± 5%

Free Chlorine 0-5 mg/l 0.01 mg/l <± 10%

Combined Chlorine 0 -5 mg/l 0.01 mg/l <± 10%

ORP 100-300 mV Na <±10%

2. DEVELOPMENT OF A PROBE WITH SELF-CALIBRATION FUNCTIONALITIES

This probe will also contain the electronics for sensor data collection and control of actuators, the power management and the telecommunications interface. 5 prototypes and a laboratory test bench will be fabricated and tested.

Finally, associated to the probe, is necessary the development of a software by INCDMTM that includes the temperature and drift effects algorithms developed by CSIC and allows the control of the probe and the acquisition of data and interface with operator.

Measurable outputs: Probe's body has to withstand pressures up to 40 bar, it has to be water proof with a minimum certified protection index of IP67. Materials will be selected to avoid bio-filming and scaling. Interface electronics will amplify and transmit sensor signal avoiding possible electrical interferences. A pressure sensor 0-20 bars will be included. Cleaning and calibration systems will be designed to minimal mechanical movement to avoid battery expense and jamming. Battery lifetime will have to be over one year with one daily cleaning & calibration. The software includes the temperature and drift effects algorithms and allows the control of the probe and the acquisition of data and interface with operator Probe's body, interface electronics, cleaning and calibration system will be developed.

The development of an ultra-low energy consumption instrument will be achieved through the combination of semiconductor sensors based on microtechnology with efficient instrumentation electronics and communications. Among these amperometric microelectrodes based-sensors work with currents in the order of μA due to their small area, which involve power consumptions of less than 100 μW. Moreover, the low impedance of ISFETs and IDEs greatly simplify the instrumentation, therefore reducing its power consumption as compared to larger, non-integrated electrodes.

3. TELECOMMUNICATIONS MODULE

This deliverable will give a prototype of telecommunications module (hardware and software) with different communications options (wired & wireless) so it can get adapted to different situations.

An enormous challenge exists on the reduction of the energy used for data communications to the minimum. This challenge requires the consecution of several works: the design of the hardware of the different communication options, the adoption of a low-energy demanding communication protocol, the minimization of transmissions and the volume of transmitted information packages. Also there exists a big challenge on how to avoid the signal problems that could raise from the tough conditions of the sampling points that would normally be underground in manholes.

A tentative communication strategy is given here: The first transmission module will be carried out using a short distance wireless communication protocol like 802.15.4 to a GPRS

Gateway that will be connected to the electric grid, this gateway will carry out the largest range transmissions using GPRS. Methods will be considered where neither mobile nor landline telephone connections are available. The data will be transferred to standard LIMS compatible databases and will be manipulated by a specially built intranet based browser interface. 5 communication modules will be fabricated and tested.

4. INTEGRATION AND VALIDATION OF THE PROBE

The probe (5 units) will be evaluated with all the elements required for its functional operation. First evaluation will be performed in INCDMTM's laboratory with water samples spiked with the target analyses. The results of this evaluation will be recorded in terms of calibration frequency, robustness, stability, etc.

Field validation tests will be performed in the water utility EMALCSA. Features like long term stability, response time, feasibility, etc. will be studied and evaluated according to the ISO 15839:2006. (Water quality. On-line sensors/ analyzing equipment for water.) (From these tests, several iterations will be carried out in order to optimize the probe and communication system. This will provide a final probe (5 units) with all improvements included for scale-up considerations.

Measurable outputs: First all parts to be integrated in one system (5 units). Validation of 5 prototypes first in lab by INCDMTM and then in field by subcontracted company EMALCSA supervised by TELLAB. The integrated system will be evaluated against parameters in table and are expected to have, as minimum, the results specified in the same table. Finally new 5 units of the final prototype will be delivered.

Table 1 Response characteristics of WIDESENS integrated system

Parameter	Concentration range	Limit of detection (LOD)	Precision
pH	4,5-10,5	N/A	< 5%
Conductivity	0- 5.000 μ S/cm	50 μ S/cm at 20oC	< 5%
Free Chlorine	0 -5 mg/l	0.01 mg/l	< 10%
Combined Chlorine	0 -5 mg/l	0.01 mg/l	< 10%
ORP	100-300 mV	N/A	<10%
Pressure	0-20 bar	0,01 bar	< 2 %



Project manager: Dr Eng. Diana Mura BADEA, tel: +40740113589; E-mail: dianamura@yahoo.com

SPECIALIZED EQUIPMENT FOR CALIBRATION IN-LINE APPLIANCES FOR TESTING PHYSICAL PARAMETERS OF WATER QUALITY

OVERVIEW:

In recent years the development of IT and communications technologies have a more significant contribution in the water processing management and the technologies for water quality control are undergoing continuous improvements. These technologies not only must comply with strict rules, safety measures, and quality standards, social and environmental challenges but also face serious problems of obsolete infrastructure, network leaks and the quality of drinking water. On the other hand, supplying clean drinking water and protecting the health of the population of the adverse effects of any contaminated water intended for human consumption are fundamental requirements of the European Directive 98/83/EC, transposed into Romanian legislation law No. 458/2002 (amended and completed by law No. 311/2004 and the Governmental Ordinance No. 11/2011).

As a result, there is a market demand for drinking water management solutions considering that current technologies are far from satisfying the legal requirements in terms of monitoring, remote transmission and data processing for water quality. To know the water quality monitoring solution currently used is manual removal of samples, in certain specific points (especially the plug), transport to laboratory, measurements and issuing a report.



TECHNICAL FEATURES:

The main technical characteristics of the specialized equipment for in-line calibration of the apparatuses for determining the physical parameters of the water quality are the following:

- Work environment: fluid (water);
- Pressure: minimum 0,7 bar and maximum 6 bar
- Working pressure: max. 3 bar
- Flow rate: $F_{\min} = 0.1887 \text{ mc /s}$; $F_{\max} = 0.55 \text{ mc /s}$; $F_{\text{work}} = 0.25 \text{ mc /s}$
- Temperature: $25 \pm 5 \text{ }^{\circ}\text{C}$
- Power supply: 50Hz; 1x230 V; 0 ... 24 VDC
- Pump: 0.016 mc /s - 0.09 mc /s
- WaterTank: 80 l

APPLICABILITY: Computerization for the day-to-day management of the infrastructure is extensively used in the field of water. As a market requirement for the field of water, given its dimension, the introduction of the automation and computerization, we can state this seems to be a must. Thus, the use of sensors, systems of registration, and transmission of data remotely, energetic autonomy are topics for companies manufacturing and distribution of water.

TECHNOLOGY TRANSFER:

The main contribution to the promotion of the technological progress in this project is focused on the innovative solutions suggested to the current concerns of computerization of the water quality measurement process.

BENEFICIARY: Privat companies, R & D institutes, technical universities.

FURTHER INFORMATION: Dumitru VLAD, e-mail: didivlad2006@yahoo.com



**WE ARE YOUR RELIABLE
PARTNER
IN EUROPEAN PROJECTS
COOPERATION AND
COLLABORATION!**

LEVEL INDICATOR WITH HALL CELLS

INCDMTM Bucharest - Phone: 021.252.30.68; Fax: 021.252.34.37; e-mail: incdmtm@incdmtm.ro

PRODUCT OVERVIEW:



Multisensory measuring system has been designed for accurate and rapid achievement of measurements level, which can be used in a wide range of applications.

This measurement system can be integrated in automated technological flows when keeping constant cell fluid level is obligatory in this case functioning as a differential level.

We can say therefore that the system allows both permanent information to the operator on the correct level, keeping level between two limits adjusted, and in case of exceeding those limits by ordering coupling/uncoupling from the facility, and storing this information on the amount of existence or transfer fluid in the reservoir.

TECHNICAL FEATURES:

The main technical characteristics of the measuring system cell HALL mutisenzor are:

- work environment: technical fluids;
- fluid density (0.5 ... 3) g / cm³
- working range (0 ... 500) mm;
- temperature: (0 ... 80) ° C;
- voltage (3,5 ... 30) V;
- current supply: 4.5mA
- response time: 5 s;
- sensitivity: 1.27 mm
- band frequency: 250 kHz.

Electronic ruler is based on two distinct systems that measure individual cell Hall liquid level located at a distance L between them. Each of these systems are consisting of a number "n" pairs of contacts placed vertically at a distance "h" between them covering the entire maximum height H_{max} of the liquid in the vessel shown in Figure 1.

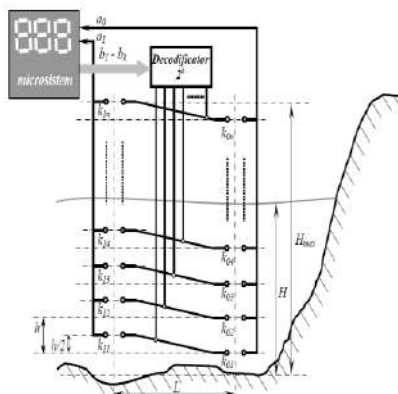

Fig.1 Scheme mounting sensors

Customer contact successively from one level to another is performed by a decoder controlled by digital micro-system ports. Thus, following the fluid density and the level is measured at a contact order to obtain a logical one on the reaction lines. If the contact is placed above the water line response is recorded logical level 0, this signal interruption command control decoder and decoder point of contact records placed above the level measured.

This multisensor measurement system is equipped with dedicated software, so measuring system will become a digital, easy to debug and minimum errors storing and transmitting information remotely.

APPLICABILITY:

Potential beneficiaries of the research are companies from the manufacturers of measurement and control equipment; necessary investments in production, introduction of new mechatronics systems are small. The implementation of new manufacturing technologies of new manufacturers will provide specialized technical assistance.

Potential users of the new products are both trading companies in the chemical and petrochemical producing, transporting and storing fluids technical and other potential users that the production process requires keeping strict fluid level on a path of transport / in inpatient or produce mixtures combining fluids and percentages are strict.

TECHNOLOGY TRANSFER:

The draft project is new and original at national level, and has a novelty and original nature at international level, being meant to generally cover a high number of issues of a pronounced applicative nature and a major social-economic impact.

The main contribution to the promotion of the technological progress in this project is focused on the innovative solutions suggested to the current concerns of computerization of the fluids measurement process.

The products resulting from the completion of the project, technical and functional characteristics improved competitiveness of the undertakings involved in capitalizing the project, both manufacturers and beneficiaries of mechatronic level measuring system, with positive effects on the economic, social and environmental.

BENEFICIARY:

Potential beneficiaries of the research are companies from the manufacturers of measurement and control equipment; necessary investments in production, introduction of new mechatronics systems are small. The implementation of new manufacturing technologies of new manufacturers will provide specialized technical assistance.

Potential users of the new products are both trading companies in the chemical and petrochemical producing, transporting and storing fluids technical and other potential users that the production process requires keeping strict fluid level on a path of transport / in inpatient or produce mixtures combining fluids and percentages are strict.

FURTHER INFORMATION:

Mrs. PhD. eng. Valentina BAJENARU – valibajenaru@yahoo.com



**COMPARTMENT OF
RESEARCH AND
DEVELOPMENT
«BIOMEDICAL AND
ROBOTIC
MECHATRONICS»**

The DIVISION OF RESEARCH AND DEVELOPMENT FOR BIO-MEDICAL MECHATRONICS AND ROBOTICS

**offers
of excellence**

Professional solutions and services:

- ✓ **Researches on scientific and laboratory devices;**
- ✓ **Researches on biomedical mechatronics;**
- ✓ **Researches on robotized technologies and devices used in medical processes.**

NACE 266;325;332

- ✓ **Medical devices and tools** ◀NACE 2660 ▶

- ✓ **Measuring, Checking and Control Devices and Tools** ◀NACE 3320 ▶

- ✓ **Measuring, Checking and Control Devices for medical processes** ◀NACE 3250 ▶

SELECTIVE LASER SINTERED COMPONENTS USED IN BIOMEDICAL RESEARCH WITH DIRECT APPLICABILITY ON SELECTED PATIENTS



PRODUCT OVERVIEW

Rapid Prototyping delivers tailor-made, flexible solutions for orthopaedics applications, with quick and cost-effective production.

They are designed in a large type and shapes to cover all kind of fractures and to assure a rapid healing.

TECHNICAL FEATURES

- Multiple form and shapes to cover all clinical situations;
- Made from biocompatible materials;
- Resistant at normal mechanical load which appears in designated implant place from human body;

APPLICABILITY

Implants must fit perfectly and be quickly tolerated by the body so they can bring about a long-term improvement in the patient's quality of life. Standard products are inadequate here. Instead, products must be tailor-fitted to the patient, with an added need for fast availability at a reasonable price.

TECHNOLOGY TRANSFER

For hospitals, clinics and medical universities

BENEFICIARY

- The research results were implemented at:
 - SC NOVA-ORL SRL
 - "FLOREASCA" Clinical Emergency Hospital
 - SC TEHNOMED IMPEX CO SA
 - "MS CURIE" Pediatric Clinical Emergency Hospital

FURTHER INFORMATION

- PhD.eng. Stanca COMSA, e-mail: stanca_comsa@yahoo.com

MECHATRONICS EQUIPMENTS FROM BIOMECHATRONICA LABORATORIES

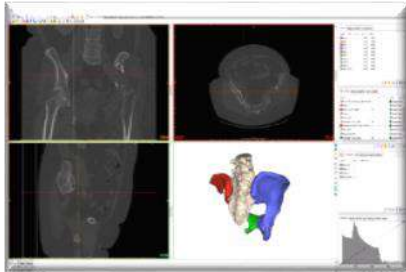

Program Graphical Interface

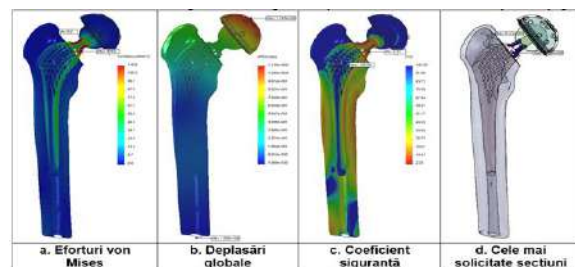

Advanced finite element analysis hip prosthesis

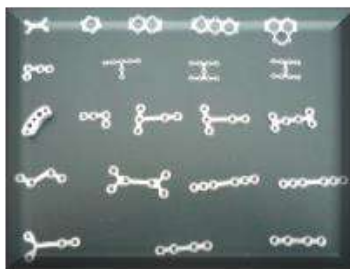

Mounting brackets maxillo - facial

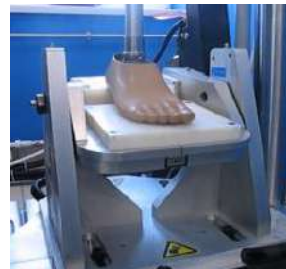

Test subassembly "ankle-foot prosthesis lower limb external"



Dental implants fatigue testing

FURTHER INFORMATION: Ph.D. Eng. Stanca Comșa, e-mail: stanca_comsa@yahoo.com

Please, visit our website: www.ijomam.com

1 / 2017

ISSN 2559 - 4397



Biannual publication



Ministry of Research and Innovation

International Journal of Mechatronics and Applied Mechanics

Mechatronics:

- Robotics and Automation
- Measurement Systems and Image Processing
- Mechatronic Systems and Manufacturing Processes
- Electronics and Cyber-MixMechatronics Systems

Applied Mechanics:

- Materials Science
- Structural Mechanics
- Fluid Mechanics
- Technology of Measurement and Instrumentation

Sponsors :



Indexed in :





**COMPARTMENT OF
RESEARCH AND
DEVELOPMENT
«MECHATRONIC MICRO
AND
NANOTECHNOLOGIES»**

The DIVISION OF RESEARCH AND DEVELOPMENT FOR MECHATRONIC MICRO AND NANOTECHNOLOGIES offers professional solutions and services:

- √ **Researches in the field of processes specific to chipping** (dynamics, kinematics, tribology):
 - Special chipping tools and high productivity tools;
 - Tools with the active part made up of tough materials (CMS, cermets, ceramic);
 - Tools with the active part made up of extra-tough materials (NCB diamond, diamond poly-crystals):
- √ **Mechatronics** technologies;
- √ Design and execution for:
 - Special chipping tools and high productivity tools;
 - Tools and subassemblies of tools;
 - Tools and subassemblies of tools and tool support assemblies for the extractive industry and the wood industry, the industry of civil engineering;
- √ Tool support assemblies and dedicated accessories for motor vehicles – theme tools;
- √ Matrices;
- √ Complex laboratory devices;
- √ Dedicated theme installations and tools used in precision mechanics and mechatronics;
- √ Special micro technologies and nanotechnologies.

NACE 267

NACE 289

NACE 711

✓ **Subassemblies for laser devices**

◀ **NACE 267** ▶
NACE 2670

✓ **Special machines and equipments**

◀ **NACE 289** ▶
NACE 2899

✓ **Industrial robots**

✓ **Technical engineering and consultancy**

◀ **NACE 711** ▶
NACE 7111
NACE 7120

✓ **Technical testing and analysis**

"MICRO/ NANOMETRIC COATINGS FOR IMPROVING THE FUNCTIONAL CHARACTERISTICS OF MECHATRONIC COMPONENTS STRUCTURES" IN NUCLEU PROGRAM "ENGINEERING OF INTELLIGENT MECHATRONICS AND CYBER-MECHATRONIC SYSTEMS / IMISC-M": Project: PN16210401

PRODUCT OVERVIEW

Study: Technical study

The project "Micro/ nanometric coatings for improving the functional characteristics of mechatronic components structures" has as main objective the achievement of researches regarding intelligent materials tribology.

General objective of the project is to investigate and to use materials for coatings of metallic parts of friction couplings used in mechatronic applications (high-precision gears in miniaturized constructions, high precision bearings, components of mechatronic equipment for measuring, positioning and adjustment: raceways, guides, grippers, etc., components for biomedical devices, MEMS & NEMS) in order to increase their lifetime. Of the many materials from which mechatronic components are done, in the framework of this project, micro/ nanostructured thin films were deposited on steel substrates, which can improve their quality.

In order to develop this objective it was necessary to achieve a technical study, which was the basis for future experimental studies. It is a field that is consistent with objective 4 of NUCLEU program "Engineering of intelligent mechatronics and cyber-mechatronic systems/ IMISC-M". Thus, the main area of interest in the project is materials science, which deals mainly with the acquisition of knowledge regarding the internal structure of materials, physical properties, and materials processing to obtain required performances in different fields of application. For example, researches on materials used in mechatronics are directed to the study of their surface properties, and the stresses to which they are subjected to.

The types of structures used at the deposition methods and characterization techniques of thin films have been analysed. Criteria by which are chosen materials for coating, and used deposition techniques: physical and chemical methods are also described.

Academic researches, of companies and performed in specialized institutes have broadened and the area of used materials/ alloys: metals (e.g. Ti, Ta and Au), ferrous alloys containing Cr, alloys based on Co - Mo - Ni - Mn - Zr - Sn - W and alloys based on Ti - Al - V - Nb - Ta - Zr, etc.

Nationally, experiments regarding deposition of titanium thin films were developed at the ICEM and INCDMFS in the years 1980-1987 and completed with technologies assimilated in manufacturing at IMF Bucharest and FS Rasnov.

Concerns regarding development of procedures and conducting experimental researches for characterization of micro- and nanostructured films, used for biomedical applications were developed also at INCDMTM.

To characterize structurally and physico-mechanically thin films obtained and applied for improvement of mechatronic components different technologies, which are presented in the same study, are used.

End of this study presents the main technical variants possible for implementation of the work; timetable of the project and describes the content and phasing of planned activities.

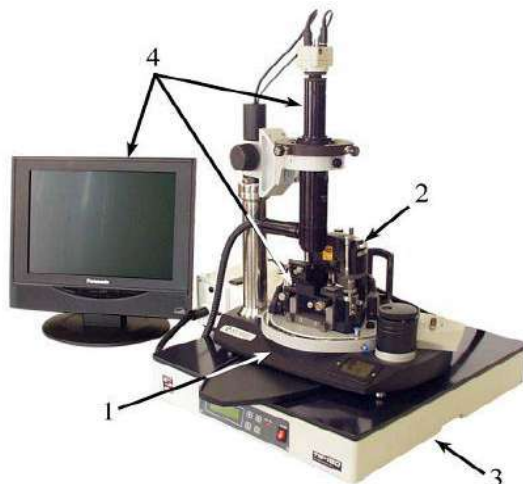

Atomic Force Microscope, NT-MDT NanoLaboratory NTEGRA Probe.

1 - basic unit; 2 - measuring probe; 3 - vibration isolation system; 4 - viewing optical system.

STUDY: Laboratory studies and researches I: structural characterization

The result of the second stage of the present project consisted of an experimental study, achieved as a result of some structural characterizations of samples studied in the project.

It is about the Ti, Cr, Al thin layers and Ti/ Al multilayer obtained by the electron beam evaporation deposition process on four types of steel: OLC45, Ru11, C120 and OSC. The deposited layers had thickness of 50 nm (Cr and Al), 100 nm (Ti), and Ti / Al multilayer had 100 nm (the thickness of each layer is 50 nm).

These samples were then characterized using atomic force microscopy and laser measurement of surfaces microgeometry.

It was observed that all the deposited layers have uniformity resulting from the deposition process, but, at the microscopic level, all seem to have not a very flat surface. Also, in the images obtained from the microscopic analysis of samples, was possible to observe the complete bonding between coating and substrate.

Following microscopic observations, to better characterize the layers, scans were performed using atomic force microscopy, which allows the characterization of surfaces up to the nanometer level. After scanning area of $50 \times 50 \mu\text{m}$ from the different films deposited on various substrates, were analysed different topographic parameters (e.g. roughness, surface skewness, coefficient of kurtosis), which provides information on distribution of deposited layer. In this way it could be done the detailed characterization of the structure of films with different thickness deposited on various substrates. The roughness was used as an indicator of deterioration of deposited layer to obtain information on the variation in height from one point to another. Surface skewness assesses the asymmetry degree of a distribution and characterizes, together with coefficient of kurtosis, the distribution form. From measurements taken it was observed that there are some

average values, minimum and maximum, of parameters obtained for thin films deposited depending on the substrate.

After analysing the average values of roughness of the deposited layers, it was observed that on the OSC type steel substrate are deposited layers with the most uniform surface. Titanium has the most uniform surface and from the thin films with thickness of 50 nm aluminium is evenly deposited on this type of substrate steel. From the measurements made it was noticed that from all steel types used as substrate, the titanium has the lowest roughness value, followed by aluminium and then chrome. The final conclusion was that were obtained layers increasingly uniform starting from chrome, aluminium and titanium. The multilayer Ti/ Al had the slightest roughness when deposited on steel substrate type C120 and the highest value of roughness when it was deposited on the steel substrate type OSC.

The average values of the surface skewness in all three types of layers deposited on the four substrates have values very close to zero, most of below 0.1 resulting that they have a symmetrical distribution. The only exception is the multilayer Ti/ Al, which has a positive surface skewness index, over 1, so it is a deposit with asymmetrical distribution to the right.

The analysis of kurtosis coefficient of the studied samples showed a platycurtic distribution (curve is flatter) of all thin films deposited on all four substrates. The exception is the Ti film with thickness of 100 nm, which has a leptocurtic distribution (height curve is higher than the normal one).

Similar results to those from AFM analysis were obtained realizing the structural characterization using the laser measuring system for microgeometry surfaces. The same surfaces with low uniformity at micro level, but with a roughness level of nm were observed.

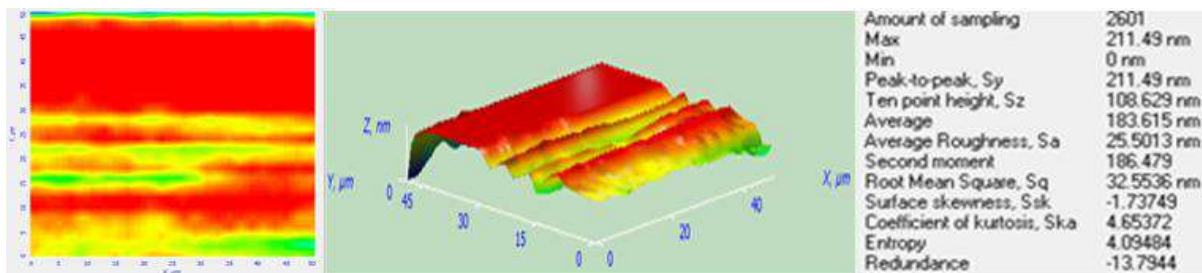

50 nm thick aluminium layer deposited on steel substrate type Rul.

TARGETED BENEFICIARIES:

- Users:
 - mechanical components manufacturers;
 - specialized departments in higher education;
 - specialized testing laboratories;
 - INFLPR, IMT, ICPE-CA, etc.
- Producers: ITMAMIRO, TEHNOROM, TEHNOMED.

FURTHER INFORMATION:

PhD. Physicist Laura Liliana Badita; e-mail: badita_l@yahoo.com

NANOTECHNOLOGICAL MEASURING SYSTEM



PRODUCT OVERVIEW

Nanotechnological measurement system is designed to calibrate devices and nanotechnology. Adaptive system is designed to be used both in the production of organized nanosystems as nanosensors and accurate transducers.

The system is equipped with two robots, displacement systems and precision laser measurement systems, opto-electronics and atomic force microscope.

TECHNICAL FEATURES:

- AFM resolution: 0.2 nm
- Laser measurement resolution: 1 nm
- Optoelectronic measurement resolution: 10 nm

APPLICABILITY:

The system can be used to calibrate the equipment and systems for nanotechnology production.

TECHNOLOGY TRANSFER:

Center of Excellence in Nanotechnology

BENEFICIARY:

Innovative SMEs in the field of micro and nanotechnology

FURTHER INFORMATION:

PhD. Eng. Popan Gheorghe; e-mail: popangeorge@yahoo.com

DISTANCE LASER MEASUREMENT SYSTEM FOR NANOSATELLITES



PRODUCT OVERVIEW:

It is a laser distance measuring system up to 1000 m. Measurement system will be used as a component of the nanosatellites measurements system required to maintain flight formation. The laser measuring system is based on time of flight method of a laser beam reflected on a target.

TECHNICAL FEATURES:

- Measuring domain: 0.066 m – 1000m
- Accuracy: ± 3 mm
- Resolution: 1mm
- Measuring rate: 200 meas./sec.

APPLICABILITY:

Highly precise measurements of distance

TECHNOLOGY TRANSFER:

The product is usable in companies producing high-tech products, R&D institutes, technical universities, including aerospace domain.

BENEFICIARY:

Institute of Space Science

FURTHER INFORMATION:

PhD. Eng. Popan Gheorghe, e-mail: popangeorge@yahoo.com

MECHATRONICS EQUIPMENTS FROM CERTIM LABORATORIES



NANOMETROLOGY FEATURES

ULTRARAPID LASER MEASUREMENT

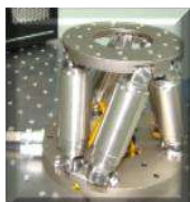

COMPLEX MEASUREMENT AND POSITIONING

FURTHER INFORMATION: Ph.D. Eng. Popan Gheorghe, e-mail: popangeorge@yahoo.com

FLEXIBLE POSITIONING MICROMECHATRONIC SYSTEM, INTEGRATED INTO TECHNOLOGICAL PLATFORMS



OVERVIEW:

The flexible positioning micromechatronic system is a modular construction and contains the following main parts:

- a worktable
- two electric linear axis model M403- 8PD of the Physik Instrumente company
- electric gripper LEHZ 32K2-22 and connections with controller
- industrial computer National Instruments PXI 8106
- electric panel
- temperature sensor
- inductive sensor
- optical barriers
- the positioning micromechatronic is electronically performed using linear gauges.

TECHNICAL FEATURES:

- worktable 1250x780x750 (mm)
- travel ranges from 0 to 200 mm on x and z axis
- carry up to 200 N and push/pull up to 50 N
- accuracy of the positioning: $\pm 0,00025$ mm;
- electrical supply: 220 V.c.a./50 Hz; (15V- CC motors, 24V- gripper and controllers)
- automatic loading and downloading of the work piece;

APPLICABILITY:

- Highly precise position for measuring.
- Mechatronic innovative system characterization of surfaces in complex vector space size, temperature
- Intelligent mechatronic system for determining the measurement of global constants in optical systems with complex software algorithms.
- System calibration inductive displacement sensors and pneumo-electric sensors.

TECHNOLOGY TRANSFER: The product is for companies producing high-tech products, R & D institutes, technical universities.

BENEFICIARY: Privat companies, R & D institutes, technical universities.

FURTHER INFORMATION: Zapciu Aurel, e-mail: zapciua@yahoo.com



**COMPARTMENT OF
RESEARCH AND
DEVELOPMENT
«STRATEGY, MARKETING»**

- ✓ **Software products realization;** ◀NACE 5829▶
- ✓ **Informatic data processing;**

- ✓ **Database; Databank services;** ◀NACE 6311▶

- ✓ **Research and development in engineering sciences;** ◀NACE 7219▶

- ✓ **Market research;** ◀NACE 7320▶
- ✓ **Strategic and operational marketing;**

- ✓ **Consultancy in management and in business;** ◀NACE 7022▶
- ✓ **Technological Transfer;**

- ✓ **Direct marketing and Advertising;** ◀NACE 7021 ▶

- ✓ **Editing activities;** ◀NACE 5811; 5812; 5814;5819▶

THE COMPARTMENT OF RESEARCH AND DEVELOPMENT «STRATEGY, MARKETING» develops

- STRATEGIES & DEVELOPMENT
- MODERN MANAGEMENT CONCEPTS
- MARKETING STRATEGIES
- CAPITALIZATION
- COST REDUCTIONS PROGRAMMES
- COMMERCIAL MANAGEMENT CONSULTANCY
- PROJECT MANAGEMENT CONSULTANCY
- SPECIALISED CONSULTANCY
- INDUSTRY LINKS
- PUBLICATION
- SUPPORT ACTIVITIES IN SUPERIOR LEARNING SYSTEM

**The Strategy, Marketing
Compartment**
in
**THE NATIONAL INSTITUTE OF RESEARCH AND DEVELOPMENT
FOR MECHATRONICS AND MEASUREMENT TECHNIQUE**
offers
the following researches in domain:

1. Researches regarding **developmentstrategy of domain and production** for precision mechanics and mechatronics, integronics and adaptronics, and Romanian industry impact in EU.
2. **Marketing researches regarding promotion of products and services** I.C.C.N Chisinau and INCDMTM Bucharest on the markets from Romania, Moldavia Republic and other countries in precision mechanics, integronics and adaptronics and mechatronics domains.
3. Researches for **restructuring strategy substantiation in precision mechanics industry, integronics, adaptronics and mechatronics domain.**
4. Researches regarding the **impact of integration in European Union** of precision mechanics, integronics, adaptronics and mechatronics industry.
5. Researches regarding **international collaboration possibilities** in investments domain for privates and state economical agents specialized in precision mechanics, integronics, adaptronics and mechatronics manufacturing in Romania, in order to align qualitatively and competitive to the same European industry.
6. Researches regarding the **tendency of European community industry** to develop Romanian markets on medium and long time in precision mechanics, integronics, adaptronics and mechatronics domain.
7. Researches regarding **connection and integration of databases** in national and European information network.
8. Researches regarding **developing of strategic marketing and modern management activities** to evaluate and innovate the European tendencies in precision mechanics (measurement technique and quality engineering, instrumentation engineering), integronics, adaptronics and mechatronics industrial domain.
9. Researches regarding growth and organization of infrastructure entities type „relay centre for transfer and consultancy”, „interregional centre for innovation and transfer”, etc.

Starting with 2017, the annual International Conference MECAHITECH goes on with a changed name.

So, please join us as we host 1st Edition of

INTERNATIONAL CONFERENCE OF MECHATRONICS AND CYBER-MIXMECHATRONICS

Please Mark Your Calendar for September 7th - 8th, 2017



You will have the chance to interact with specialists around the globe in the exciting world of innovation and new scientific discoveries.

► The Conference Proceedings of ICOME CYME is published by SPRINGER Publishing House

Based on a single blind evaluation, selected papers will be listed in the International Journal of Mechatronics and Applied Mechanics – IJOMAM (www.ijomam.com) which is indexed in SCOPUS, EBSCO and PROQUEST. Each paper published in this scientific journal has a DOI assigned.

For more information please contact us at incdmtm@incdmtm.ro or access conference Website: <http://incdmtm.ro/icomecyme2017?lang=en>

Scope

The conference aims to promote scientific research results, technological development and innovation in Europe, but also to familiarize participants in other countries with the Romanian state of the art in **mechatronics, applied mechanics, cyber-mixmechatronics and other specialized smart fields**, by facilitating the interaction and exchange of experience and good practice between specialists in universities, research institutes and private companies.

CONFERENCE ORGANIZERS:



National Institute of Research and Development in Mechatronics and Measurement Technique, Bucharest - Romania



Relay Center of Technological Transfer and Consultancy



MECHATREC - Regional Cluster in Mechatronics Bucharest-Ilfov

CO-ORGANIZERS:



Ministry of Research and Innovation



University „Concordia” Montreal, Canada



Institute for Water Education – UNESCO – IHE, Delft, Olanda



Academy of Technical Sciences of Romania



Futuracluster.eu
Futura Cluster



Disemination and Publications

The Strategy, Marketing Department contributes to the disseminating of the institute results by designing and producing posters, ads, flyers, brochures, DVDs for all the scientific events organized by the institute.

The Strategy, Marketing Department also deals with editing the scientific publications, namely scientific books, catalogues, reports and **the scientific journal**. Since 2017, the former *Romanian Review Precision Mechanics, Optics and Mechatronics* will become the International Journal of Mechatronics and Applied Mechanics

International Journal of Mechatronics and Applied Mechanics is a publication dedicated to the global advancements of mechatronics and applied mechanics research, development and innovation, providing researchers and practitioners with the occasion to publish papers of excellent theoretical value on applied research. It provides rapid publishing deadlines and it constitutes a place for academics and scholars where they can exchange meaningful information and productive ideas associated with these domains.

The *journal* provides its readers with critically peer-reviewed, carefully selected articles about advances in the fields of mechatronics and applied mechanics.

Promotional materials:

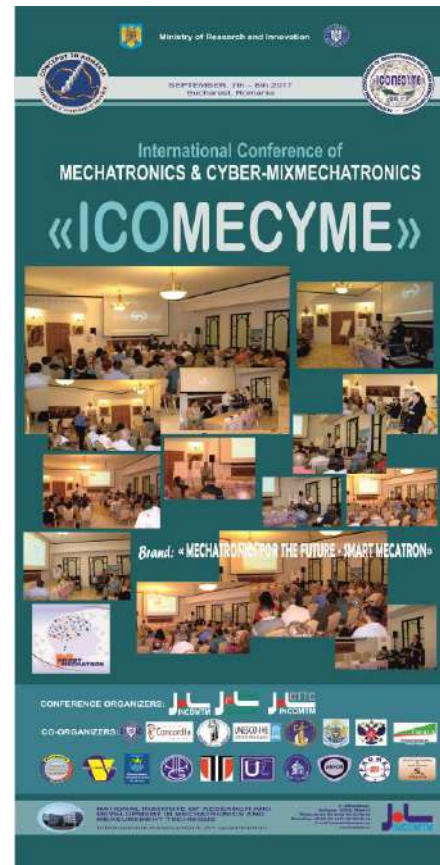

Scientific publications



Papers published in *IJOMAM* bring an intellectual approach to knowledge, experience and learning. Moreover, these works establish an obvious connection between professors, researchers and highly qualified experts in the approached fields as papers appeal to a wide range of audiences interested in Mechatronics and Applied Mechanics all around the world.

Topics cover two main areas: Mechatronics and Applied Mechanics. Each main topic is structured in 4 sub-areas (8 fields of research for the journal), each with an Associate Editor assigned:

- *Under the Mechatronics topic:*

- Robotics and Automation
- Measurement Systems and Image Processing
- Mechatronic Systems and Manufacturing Processes
- Electronics and Cyber-Physical Systems

- *Under the Applied Mechanics topic:*

- Materials Science,
- Structural Mechanics,
- Fluid Mechanics,
- Technology of Measurement and Instrumentation.

International Journal of Mechatronics and Applied Mechanics is a peer-reviewed, open-access journal, published twice a year, in July and November, and is included in EBSCO, SCOPUS and ProQuest international databases (IDB).

International Journal of Mechatronics and Applied Mechanics



If you have any questions on the submission and reviewing process, please contact the Editorial Team at incdmtm@incdmtm.ro

For more information please access journal Website: <http://ijomam.com>

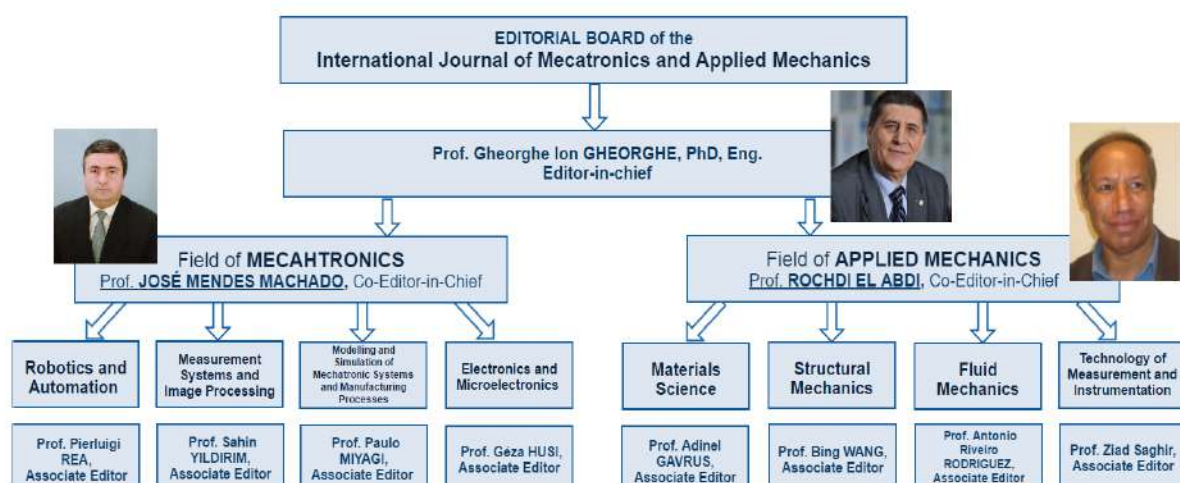

Event management

Event management is also an important tool for the institute's marketing and communication activity. The marketing team effort helps researchers to benefit from promotional events as a way to communicate with current and potential partners.



Our **STRENGTHS** are:

- We have a young, dynamic team with experience in organizing national and international events
- We have a strong relationships with our partners
- We are reliable
- We have an well developed system for registration, abstracts and papers collection, communication with participants
- We are friendly and open to suggestions



What we **DO BEST** (from our previous experience):

- International and National Conferences
- Symposia
- Thematic workshops
- Ad hoc groups for international exchanges
- Meetings
- Projects meetings and events
- Laboratory visits
- Detachments for European collaborations
- Management of individual participants for conferences



Please, visit our website: www.ijomam.com

2 / 2017

ISSN 2559 - 4397



Biannual publication



Ministry of Research and Innovation

International Journal of Mechatronics and Applied Mechanics

Mechatronics:

- Robotics and Automation
- Measurement Systems and Image Processing
- Mechatronic Systems and Manufacturing Processes
- Electronics and Cyber-MixMechatronics Systems

Applied Mechanics:

- Materials Science
- Structural Mechanics
- Fluid Mechanics
- Technology of Measurement and Instrumentation



Sponsors :



Indexed in :





**COMPARTMENT OF
RESEARCH AND
DEVELOPMENT
«INTEGRATED
MANAGEMENT»**

INTEGRATED MANAGEMENT SYSTEM (IMS) CERTIFICATION IN FIVE STEPS

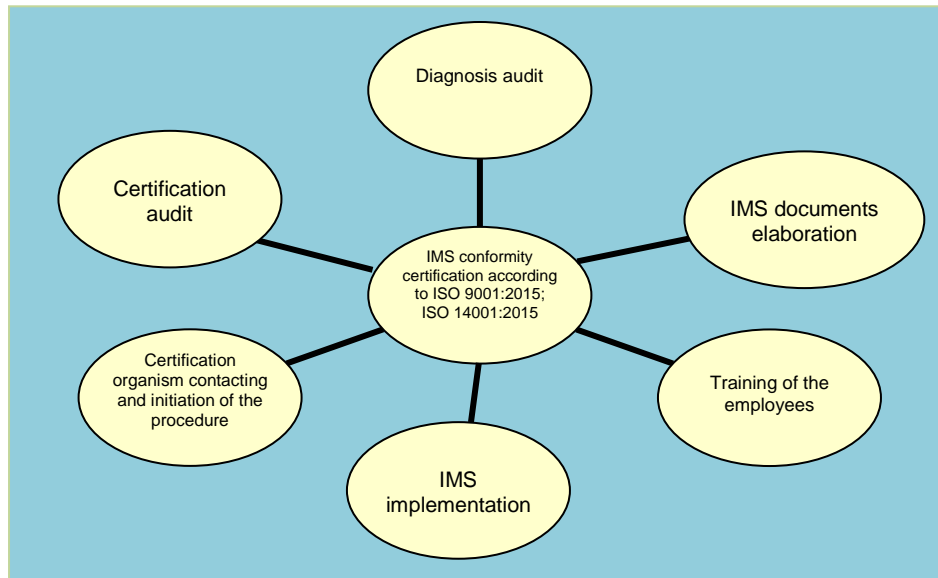

TECHNICAL AND FUNCTIONAL FEATURES:

- ◇ Duration until obtaining the certification – 5 months
- ◇ Assistance during the certification audit
- ◇ Internal audit services and assistance during availability of the certificates
- ◇ National and international recognition of certificates

APPLICABILITY:

- ◇ **Competitive advantage:** certified firms confirm the development of new businesses.
- ◇ **Increase in the demand by clients:** certified firms report an increase in the demand from clients, and, automatically an increase in business.
- ◇ **Business protection:** firms that are not certified have declared that they have lost clients who have preferred certified organizations. They have found out when losing contracts is already too late.
- ◇ **Cost reduction:** through efficiency, continuous improvement, loss diminishing, key control of processes.
- ◇ **The competition is certifying:** in many fields, concurrent are certified or are being certified. The more you wait before doing it, the bigger will the competition advantage be.
- ◇ **New prospects:** certified firms want to have certified business partners.
- ◇ **You will be qualified for the participation in public acquisitions.**
- ◇ **Increase in credibility:** Your businesses can increase dramatically, taking into account that many firms only work with certified firms.

CAPITALIZATION AND TECHNOLOGY TRANSFER:

Seng. Carmen Finat; carmen.finat@incdmtm.ro

THE RESEARCH IN INTEGRATED MANAGEMENT DEPARTMENT HAS AS PRIMARY FIELDS OF EXPERTISE

- 👍 Execution of research – development projects focused on quality management and environment issues;
 - 👍 Methodological coordination of the certified laboratories of INCDMTM;
 - 👍 Development and implementing of quality management or integrated systems for: organizations, trial labs, management systems certifying entities, product certifying entities, inspection entities;
 - 👍 Internal and external audits of the quality management system;
- Standardization**, standard development, attending in Technical Standardization Committees;

Research objectives of the CCMI personnel:

- attending participation in competitions through project C – D proposals;
- execution of C – D projects
- elaboration and editing of technical and scientific materials designed for presentation and informing purposes.
- Participation in development of scientific standards for the departments tied of expertise.

The CMI personnel abilities for:

- ↪ The completion of all activities assigned to CMI, with the regard for the specific conditions and terms subsequent from the procedure which documents the quality manage system;
- ↪ Identifying and registering any and all problems concerning processes, products and for the integrated quality management system;
- ↪ Annual management analysis;
- ↪ Initialization and conduction on Internal Audit Programs;
- ↪ Identifying of professional training needs inside the CMI ;
- ↪ Follow up of the training activities and training evaluation participation in INCDMTM;
- ↪ Participation in the analysis of bids, orders and contracts;
- ↪ Involvement in the assessment and selection activity of subcontractors;
- ↪ Timely elaboration at a scientific level of all the works assigned to CMI;
- ↪ Projects elaboration concerning the main activity field of CCMI and the department's personnel.

The concerning domains of CMI are part of the interest domain set of INCDMTM and are based on the following fundamental management principles:

- ❖ Clients explicit and implicit needs satisfaction;
- ❖ Quality level assessment opposed to the degree of correspondence with the client's

needs;

- ❖ Prevention, as an economic solution for the improvement of the integrated quality management system;
- ❖ Planning of the activities / processes of INCDMTM;
- ❖ Perfecting internal communication in INCDMTM;
- ❖ Promoting a quality based value system.

The main objectives of CMI are:

- ↳ **Continuous improvement of the integrated quality management system implemented in INCDMTM and keeping conformity with the referred standard SR EN ISO 9001: 2015 and SR EN ISO 14001: 2015 ;**
- ↳ **Project proposals participation** at the National and International Research – Development Innovation Programs;
- ↳ **Maintaining the certifications of the laboratories placed under the legal authority of INCDMTM according to the conditions of the referral SR EN ISO / CEI 17025**

CMI is enabled and competent to deal with the development of the following third party works:

Ensuring a high level of competitiveness for the organizations / trial labs by giving assistance with the integrated quality management system for:

- technical and administrative assessment, identification of processes / sub processes of the organization, development of the establishment based on the processes existing in the lab / organization, by taking into consideration of all the conditions and norms concerning quality and quality management;
- ensuring the good functioning of the organization's processes according to the requested standard conditions of document elaboration;
- ensuring the success of developing integrated quality management system through an appropriate documentation of the processes from the organizations/labs, through the development of quality management system / integrated management system;
- development of an adequate management system documentation of the processes/ sub processes and activities that take place in the organization, in accordance with the organizational culture, with its objectives the services / products it provides, with the referral standards and / or other legal / normative requirements.
- ensuring the success of quality management system, implementation, maintenance and continuous, improvement inside organizations / trial labs by providing consulting and / or technical assistance.

Main areas of interest of the CMI in the standardization domain

In full accordance with the national policy of standardization, CMI participates at the assimilation of European standard process by assigning a representative of CMI in the Technical Standardization Committee.

Also from the standardization point of view, CMI has responsibilities in ensuring a human interface with the consequent department of ASRO and in maintaining a standardization data base in INCDMTM.



ACTIVITY CONTROL IN INDUSTRY LINKS OFFICE

- ↪ **constituting a database with potential internal and external product/ technology/ service purveyors – OFFER and with participants at technological transfer – DEMAND from precision mechanics, mechatronics and connected domains;**
- ↪ **facilitation of information transfer to the partners;**
- ↪ **participation at negotiation of technology transfer;**
- ↪ **promotion, by various ways, of current and perspective necessities of economical agents;**
- ↪ **rational maintenance with some other technological transfer centers from different domains;**
- ↪ **consultancy and assistance regarding the participation in RD projects launched by the European Union.**



**THE RELAY CENTRE FOR
TECHNOLOGY TRANSFER
AND CONSULTANCY**

- CRTTC – INCDMTM •

RELAY CENTRE FOR TECHNOLOGY TRANSFER AND CONSULTANCY

- **Authorized, MENCs**
- **Accredited ISO 9001/ 2001**



HM Version 4.0.10 Examples - Microsoft Internet Explorer

File Edit View Favorites Tools Help

Address <http://www.centrutransfer.ro>

Colaboratori
Aplicatii
Produse
INCDMF
OLI
Centrul Interregional
Listeaza Unitati
Adauga Unitati
Oferta Centru de Transfer-CRTTC
Studiu de fezabilitate CIIT:ELIRI, S.A. -Chisinau
Studiu de fezabilitate CIIT: INCDMF, Bucuresti
Centre de Transfer
Contact
Home

O Noua Abordare
TRANSFER TEHNOLOGIC SI CONSULTANTA
Afaceri Valorificare Consultanta Transfer Tehnologic

Vizitati site-ul www.centruinterregional.ro

Centrul Releu de Transfer Tehnologic si Consultanta
pentru Industria Mecanica Fina, Mecatronica si Domenii Conexe
INCDMF - CEFIN - Bucuresti
► functioneaza, in baza ORDINULUI NR. 130 din 20.05.1998 - MCT (ANSTI)

www.centrutransfer.ro

RELAY CENTER OF TECHNOLOGICAL TRANSFER AND CONSULTANCY

•CRTTC•

THE FUNDAMENTAL OBJECTIVE AND THE OPTIONS OF STRATEGY

RELEVANT THROUGH Relay Center of Technological Transfer and Consultancy – CRTTC –

[A] **The fundamental objective in the medium term:**

- (1) creation by TECHNOLOGICAL TRANSFER of some sub-sectors of fine mechanics, optics and mechatronics for a functioning market, compatible with the EU principles, rules, mechanisms, institutions and policies;
- (2) shaping the convergence of technological transfer activities, based both on evaluation of resources and opportunities, and on national and international context;
- (3) support the imperative to conclude the transition of TECHNOLOGICAL TRANSFER to market economy in the field of industrial fine mechanics, optics and mechatronics as well as preparation of the accession of industries Fine mechanics, optics and mechatronics in industrial fields related EU;

[B] **Options of the corresponding strategy of basic objective options aim to create conditions for:**

- (1) providing specific industry sectors increased proportion of fine mechanics, optics and mechatronics based on technology transfer and increase investment rate, both through a significant participation of national capital and by attracting external resources;
- (2) further measures to stabilize the specific sub-industry of fine mechanics, optics and mechatronics through support for technology transfer for the domain and policies to ensure the budget deficits incurred and the dynamic quasi-fiscal deficit reduction in the specific industry;
- (3) the promotion and integration of technology transfer and coherent policies are compatible with EU mechanisms, aimed at "adjusting" fine structural mechanic, optics and mechatronics, development and modernization of specific sub-area, revitalization and upgrading of sub-sectors and that some businesses related sub, supporting implementation of information technology in the automation industry and specifically by his computerization of other industrial sectors of developing the national strategy;
- (4) providing an optimal environment TRANSFER OF TECHNOLOGY AND BUSINESS, specific market area based on the development of market competition, by reducing costs and easing the tax burden and promoting specific measures to stimulate small and medium enterprises;

- (5) modernization and development of technology transfer and industrial services and other specific fields to best meet the needs and requirements of the internal market (and external), and approaching the standards the EU countries;
- (6) increasing technology transfer and the remodelling of the structure of industrial production capacity and the related field of fine mechanics, optics and mechatronics, including the development and fostering cooperation with EU partners, including entities related to technology transfer infrastructure, amid consolidation operation market economy, it real infrastructure of a competitive environment and the renewal of SMEs with potential competitiveness;
- (7) sequence selection process for resizing and operators in the field of fine mechanics, optics and mechatronics, engaged in restructuring and economic recovery by absorption of the most effective technology transfer of R & D results;
- (8) developing the technology transfer consultancy and training, entrepreneurial training and business in centre field-specific relay transfer of fine mechanics, optics and mechatronics, which facilitates the provision of useful services for SMEs;
- (9) improving project management research and development-innovation and technology transfer and capacity development to generate scientific and technological knowledge in the field of fine mechanics, optics and mechatronics, in order to reduce disparities in technology, information infrastructure development, application of standard procedures for assessing of operations and personnel, developing the capacity to disseminate scientific knowledge and technology infrastructure transfer extension and marketing services, industry liaison offices, business centres and centres of excellence;
- (10) developing capacity of the innovation in the economic environment, by developing the field of fine mechanics, optics and mechatronics, and that the technological transfer of results in this priority area.

MISSION:

1. **Awareness of companies in the industry, the necessity and importance of technology transfer;**
2. **Constant involvement Relay Technology Transfer Center and Consultants share the results of RDI technology transfer.**

FURTHER INFORMATION:

Drd. Eng. Iulian Ilie, Manager

Phone: +4021.252.30.68/361

e-mail: iuliancefin@yahoo.com

INTELLIGENT MECHATRONIC SYSTEM FOR HIGH PRECISION MEASUREMENT OF LINEAR MICRO-MOUVEMENTS IN INDUSTRIAL AND LABORATORY ENVIRONMENTS - DIGITIL

Technology transfer

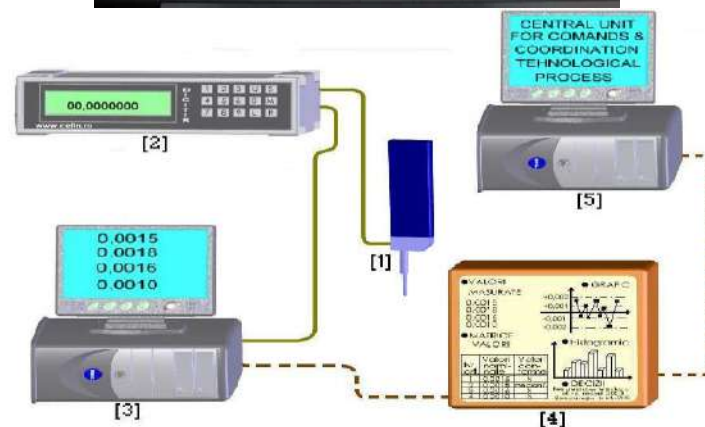

PRODUCT OVERVIEW:

The intelligent micro-system – DIGITIL includes the following innovative components / modulus:

- Incremental photoelectric transducer (1) for measurement of micro-displacements -and incremental divider scale with detail of original incremental network ;
- Electronic subsystem digital unit for measurement and display (2) ;
- Informatics unit PC (3) – and the functional block diagram;
- LCD monitor (4);
- Central informatics unit PC (3);

DIGITIL has an original configuration of intelligent mechatronic micro-system for measurement in continue flux (Original solution for the construction of the intelligent transducer; Original solution for the

linear incremental photoelectrical network divisor kind / vernier kind and the incremental network of zero; Original solution for the construction of the electronic unit for measurement, display and transfer; Original software for the process of measurement, comparison, representation and transfer; Original system for the electronic pitch of impulses; Lower energetic consumption for the entire micro – system; Lower ambience noise, network noise and other electromagnetic noises; Compensation of the amplifiers offset), quick measurement in real time, micron precision of measurement per measurement interval, Efficient control of data measured (that are acquisitioned and storage).

The intelligent system – DIGITIL includes the following innovative components / module:

- [1] Photoelectric incremental transducer for measurement of linear micro-movements
- [2] Electronic unit for digital measurement/display
- [3] Informatic unit PC
- [4] Electronic unit for registration and representation
- [5] Central unit for commands and coordination

TECHNICAL FEATURES

- Dimensions (L x l x h – in mm): 600 x 550 x 880.
- **Measurement interval:** 10mm; (and 30; 50; 80;100mm for product development);
- **Resolution (R) :** 0,001mm ;(and 0,0001mm; 0,00001mm for product development)
- **Accuracy :** $\pm 0,001$ mm $\pm 0,0001$ mm for product development);
- **Display capacity:** 8 decade +1 decade for sign;
- **Supply IRED:** $+(5\pm 0,25)V$;
- **Supply for electronic unit:** 220V; 50 Hz $\pm 2\%$;
- **Electronic sub-partitions:** logical(2,4,6) and analogical(5,10,20);
- **Counting error:** \pm bit; **Accuracy error:** max. $\pm R/8$;
- **Electrical impulses frequency:** 0÷100 Hz;
- **Impulses filling factor:** $a/p = 0,5 \pm 0,1$;
- **Shift of impulses:** A and B : $b/p = 0,25 \div 0,05$;
- **Signals output:** TTL and with free collector.

APPLICABILITY

The product is used in very accurate linear measurements in static and dynamic, very precise linear positioning in static and dynamic, equipped as CN and CNC system on machine tools and other equipment; equipped as CN and CNC system on industrial and control robots / micro robots; equipped as intelligent mechatronic systems for measurement and control, or complex instruments / devices and equipments for control and measuring in 1D, 2D and 3D.

TECHNOLOGY TRANSFER: This technology / product were transferred to S.C. QUATRO PRODCOM S.R.L.

BENEFICIARY: S.C. QUATRO PRODCOM S.R.L., Dr. Eng. Ghiorghe Stoica

FURTHER INFORMATION: Professor PhD.EurEng Gh. Ion GHEORGHE / Tel. 021.252.30.68/69, Fax. 021.252.34.37, e-mail: geo@cefin.ro ; geocefin@yahoo.com

INTELLIGENT MECATRONIC MICRO-SYSTEM FOR DIMENSIONAL MEASUREMENT FOR HIGH PRECISION MEANT TO DEVELOPMENT OF INSTRUMENTATION ENGINEERING IN INDUSTRIAL AND LABORATORY ENVIRONMENTS - DIGITRIL

Technology transfer

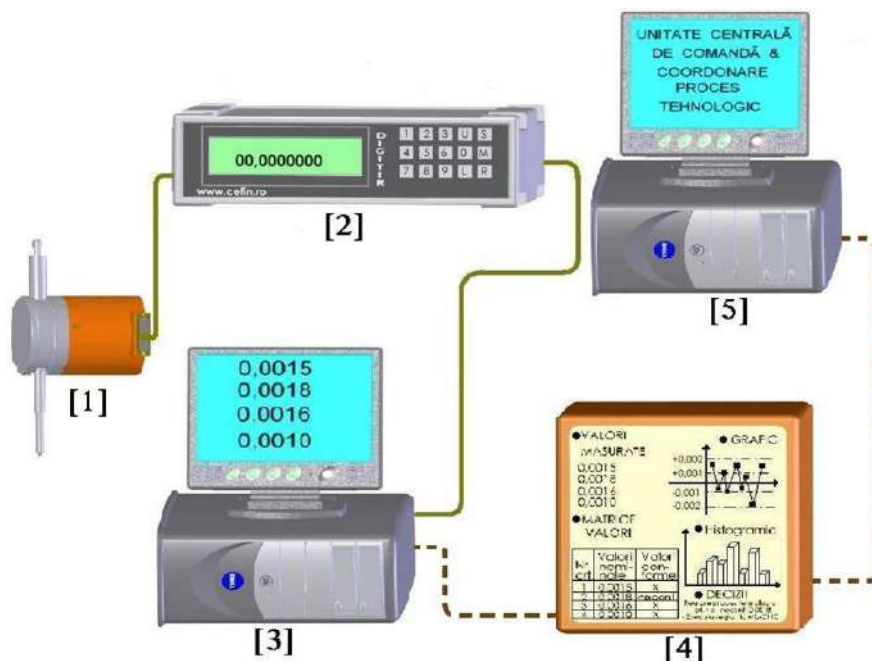

PRODUCT OVERVIEW:

The intelligent micro-system – DIGITRIL includes the following innovative components / modulus:

- [1] Photoelectric incremental transducer for measurement of linear micro-movements
- [2] Electronic unit for digital measurement/display
- [3] Informatic unit PC

[4] Electronic unit for registration and representation

[5] Central unit for commands and coordination

DIGITRIL is designed for positioning / micro positioning and, equipment of technical and technological installation MECHATRONICS equipment as a - CN and / or CNC system mechatronic.

The claimed novelties are: original solution for the construction of the intelligent transducer; original solution for the linear incremental photoelectrical network divisor kind / vernier kind and the incremental network of zero, original solution for the construction of the electronic unit for measurement, display and transfer; original software for the process of measurement, comparison, representation and transfer; original system for the electronic pitch of impulses; lower energetic consumption for the entire micro system; lower ambience noise, network noise and other electromagnetic noises; compensation of the amplifiers offset; quick measurement, in real time; micron precision of measurement per measurement interval; efficient control of data measured (that are acquisitioned and storage); original dedicated software which signalize promptly with audio and video messages(included a hold on of the measurement process) when a measured product is no conform (it is not in the tolerated field established at the start of the process).

TECHNICAL FEATURES

- Dimensions (L x l x h – in mm): 600 x 550 x 880.
- **Measurement interval:** 10mm; (and 30; 50; 80;100mm for product development);
- **Resolution (R) :** 0,001mm ;(and 0,0001mm; 0,00001mm for product development)
- **Accuracy :** $\pm 0,001$ mm $\pm 0,0001$ mm for product development);
- **Display capacity:** 8 decade +1 decade for sign;
- **Supply IRED:** $+(5\pm 0,25)V$;
- **Supply for electronic unit:** 220V; 50 Hz $\pm 2\%$;
- **Electronic sub-partitions:** logical(2,4,6) and analogical(5,10,20);
- **Counting error:** \pm bit; **Accuracy error:** max. $\pm R/8$;
- **Electrical impulses frequency:** $0\div 100$ Hz;
- **Impulses filling factor:** $a/p = 0,5 \pm 0,1$;
- **Shift of impulses:** A and B : $b/p = 0,25 \div 0,05$;
- **Signals output:** TTL and with free collector.

APPLICABILITY

The product is used in very accurate linear measurements in static and dynamic, very precise linear positioning in static and dynamic, equipped as CN and CNC system on machine tools and other equipment; equipped as CN and CNC system on industrial and control robots / micro robots; equipped as intelligent mechatronic systems for measurement and control, or complex instruments / devices and equipments for control and measuring in 1D, 2D and 3D.

TECHNOLOGY TRANSFER: This technology / product were transferred to S.C. QUATRO PRODCOM S.R.L.

BENEFICIARY: S.C. QUATRO PRODCOM S.R.L., Dr. Eng. Ghiorghe Stoica

FURTHER INFORMATION: Professor PhD.EurEng Gh. Ion GHEORGHE / Tel. 021.252.30.68/69, Fax. 021.252.34.37, e-mail: geo@cefin.ro ; geocefin@yahoo.com

INTELLIGENT SYSTEM WITH PHOTOELECTRIC TRANSDUCER WITH INCREMENTAL DISCS FOR MEASUREMENT OF ANGULAR MOTIONS - DIGITIR

Technology transfer

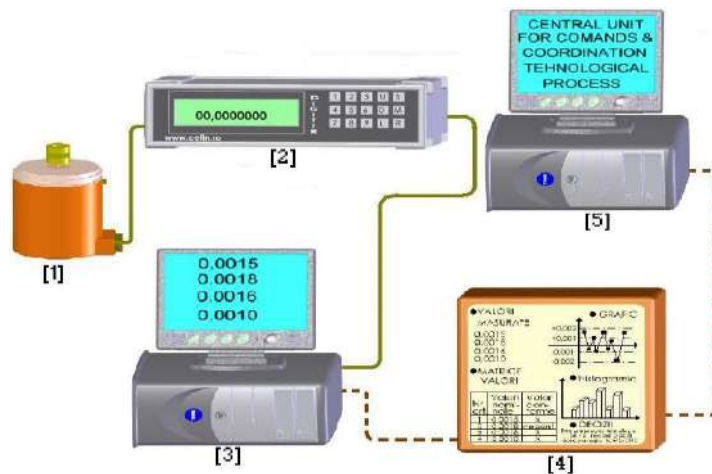

PRODUCT OVERVIEW

The intelligent system with incremental disks photoelectric transducer for dimensional and angular displacements measurement in industrial environment is intended for positioning / micro-positioning, direct measurements, angular displacements / micro-displacements and equipping as NC and/or CNC system, technical and technological installations and equipments.

The intelligent system, converts an analogical quantity (angular displacement) in a digital quantity (number of impulses).

The intelligent system, by photoelectric transducer subsystem supplies at exit four rectangular signals in quadrature and zero signals.

An adequate processing of those signals in electronic subsystem for measurement and digital display, allows electronic sub-partitions with 2, 4, 8 (in case of analogical exits can be made sub-partitions with 2, 4, 5, 10, 20) and detection of angular displacement orientation.

The intelligent system – DIGITIR includes the following innovative components / modulus:

- [1] Photoelectric incremental transducer for rotation
- [2] Electronic unit for digital measurement / display
- [3] Informatic unit PC
- [4] Electronic unit for registration and representation
- [5] Central unit for commands and coordination

Based on binding heights, the beneficiary can built different assembling systems of photoelectric transducer subsystem, adequate to various applications, with condition of respecting subsystem characteristics. Axis of rotation is made of non-corrosive steel hardened / tempering. Mechanical coupling is made through precision elastic systems.

TECHNICAL FEATURES:

- **Dimensions (L x l x h – in mm): 600 x 550 x 880.**
- **Measurement domain:** infinite; **rotation angle** is ∞ ; **measurement interval** $0^{\circ} \div n \cdot 360^{\circ}$;
- **Resolution :** $R = \frac{360^{\circ}}{N}$, [°, ', "] ; where :N = number of impulses / rotation;
- **Accuracy** (correctness error): max. $\pm R/4$;
- **Hysteresis value:** max. $\pm R/7$;
- **Accuracy error:** max. $\pm R/8$;
- **Null impulse width:** max. R;
- **Electrical impulses frequency:** $0 \div 100$ Hz;
- **Null impulse** (reference): one at 360° ;
- **Impulses filling factor:** $a/p = 0,5 \pm 0,1$;
- **Shift of impulses:** A and B : $b/p = 0,25 \div 0,05$;
- **Signals output :** TTL and with free collector
- **Photoelectric transducer subsystem weight:** max. 0,5 kg
- **Overall size** (photoelectric transducer subsystem: max. $\varnothing 58 \times 95$ mm);
- **MTBF :** 1500 hours;
- **R (550 h):** 0,9 ;
- **R (950 h):** 0,76 ;
- **Z (550 h):** $2,8 \cdot 10^4 \text{ h}^{-1}$;
- **Z (950 h):** $4,4 \cdot 10^4 \text{ h}^{-1}$;

APPLICABILITY: The product is used in very accurate linear measurements in static and dynamic, very precise linear positioning in static and dynamic, equipped as CN and CNC system on machine tools and other equipment; equipped as CN and CNC system on industrial and control robots / micro robots;

TECHNOLOGY TRANSFER: S.C. QUATRO PRODCOM S.R.L.

BENEFICIARY: S.C. QUATRO PRODCOM S.R.L., Dr. Eng. Ghiorghe Stoica

FURTHER INFORMATION: Professor PhD.EurEng Gh. Ion GHEORGHE / Tel. 021.252.30.68/69, Fax. 021.252.34.37, e-mail: geo@cefin.ro ; geocefin@yahoo.com



**INTER-REGIONAL CENTER OF
INNOVATION AND
TECHNOLOGY TRANSFER
CHISINAU – IASI –
BUCHAREST**



INTER-REGIONAL CENTER OF INNOVATION AND TECHNOLOGY TRANSFER CHISINAU –IASI –BUCHAREST

WHO ARE WE?

- ✓ **CIITT** is “an inter-regional centre of innovation and technology transfer” associated with applied research institutions, universities and academic environment in Moldova and Romania;
- ✓ **CIITT** is an official collaborator of the Ministry of Education, Research, Education and Youth and the Ministry of Economy, Commerce and Business Environment, for disseminating information and promoting technology transfer and research results;
- ✓ **CIITT** is a partner in economic institutions and units from different industries in Romania and Moldova, for support and the process of technology transfer and consultancy;

FIELDS OF COMPETENCE:

- Information sharing
- **Consulting**
- Industrial Services, Commercial
- Technology Transfer for Products / Technologies / Services
- **Management and marketing**
- **Database**
- Information Products

MANAGEMENT & MARKETING:

- Human Resource Management
- Project Management
- Management of SME
- Information Management
- Management of Research
- Industrial Marketing
- Market research (product / technology / services)

STRATEGY & DEVELOPMENT:

Development strategy for the following industries:

- Precision Mechanics & Mechatronics & Integronics and Adaptronics;
- Electronics and Electrical engineering;
- Construction machinery
- Strategy & Development of SMEs in industrial and economic environments mentioned;
- Medium and long term strategy of the areas mentioned in light of EU accession.



**THE NATIONAL SCIENTIFIC
CLUSTER «MICRO-NANO-
MECATRONICS»**

NATIONAL SCIENTIFIC CLUSTER “MICRO-NANO-MECHATRONICS”

OVERVIEW:

Beginning with the INITIATION PROTOCOL/1058 & 167/30.08.2007 for NATIONAL SCIENTIFIC CLUSTER MICRO-/NANO TECHNOLOGIES for MECHATRONICS, SENSORS AND ROBOTS performed between INCDMTM-Bucharest and the UNIVERSITY “POLITEHNICA” - RESEARCH AND DEVELOPMENT CENTER FOR MECHATRONICS, that put the basis of excellence scientific researches in the HIGH-TECH field of micro-nano-technologies for mechatronics, sensors and robots for an advanced and sustainable consideration of this domain for reaching EU levels of performances and compatibility - European area of research and also regarding The LISBON strategy.

- is responsible and coordinates at national level, advanced scientific researches for micro-nano-technologies for mechatronics, sensors and robots: development of new products micro-/nano-/mechatronics:micro-/nano-/sensors,micro-/nano-/actuators,mini-/micro-/nano-/robots; development of new micro-/nano-/intelligent systems: for new HIGH-TECH domains of microelectronics and electrotechnics, aerospace, micro-/nano-/mechatronics, for new domains MID-HIGH-TECH and LOW-HIGH-TECH;
- development of new advanced systems for integrated manufacturing processes: (a) off-process: ultra-precise systems for integrated control and monitoring for different industrial environments; (b) on-process: high accurate intelligent systems for interface control and quality evaluation for industrial issues;
- development of new principles, methods and high performances techniques: optical-electronic, laser, ultrasonic, piezoelectric etc.;
- development of micro-/nano-/technologies: (a) litho-photography; (b) chemical corrosion; (c) micro lasers; (d) thin layers; (e) LIGA; (f) physical/ chemical; (g) micro-machinery;
- development of frictional technological system researches: (a) frictional systems specific to cuttings and micro-cuttings; (b) frictional systems specific to friction torques; (c) characterization of micro-/nano-/ covering structures; (d) dynamic testing with or without lubrication;
- development of new intelligent materials: (a) hard and extra-tough materials; (b) composite materials; (c) ceramics materials; (d) direction properties materials; (e) processing and characterization materials;
- development of equipments and techniques for analysis and environmental control;
- development of intelligent medical techniques: (a) virtual with guiding through neuro-images for microsurgery and neurosurgery; (b) therapy with implant-prosthesis for controlled bone regeneration; (c) connections for securing techniques of data given by clinical and laboratories devices; (d) new joint generating techniques;
- is responsible and coordinates at national level of research-development infrastructure achievement using WHITE-CHAMBERS for micro-/nanotechnologies for mechatronics, sensors and robots;
- is responsible and coordinates of research-development infrastructure achievement i.e. “Pole of excellence for Mechatronics” within the project belonging to – IMPACT-STRUCTURAL FUNDS: (a) building-located nearby Mechatronic and Precision Mechanics Department in Polytechnic University Bucharest; (b) technical and technological environment specific to WHITE CHAMBERS;
- participates and elaboration Inventing Developing Research projects within National and European Programs, at their open competitions, as a coordinator and/or partner;
- participates and initializing and organizing National Technology Platforms on certain domains, similar to European ones, developing research activities, projects elaboration, information disseminating, marketing, training etc.;
- participate at the organizing of technical-scientific events and manifestations, elaborates scientific works for symposium, conferences/ scientific national and international congress;
- develops contact/contracts with institutions/ associations for research similar in EU.;
- it functions based on its own Regulations, commonly established with CLUSTER entities.

FURTHER INFORMATION: Professor PhD.EurEng Gh. Ion GHEORGHE / Phone: 021.252.30.68/69, Fax:021.252.34.37, e-mail: geo@cefin.ro ; geocefin@yahoo.com



**THE REGIONAL INNOVATIVE
CLUSTER BUCHAREST-ILFOV IN
THE FIELD OF MECHATRONICS,
INTEGRONICS & ADAPTRONICS
«MECHATREC»**

«MECHATREC» REGIONAL INNOVATIVE CLUSTER

• Purpose of MECHATREC Regional Cluster

Regional Cluster MECHATREC goal is the implementation and development, during preliminary time of its own strategy, by:

- Presenting, promoting, supporting and defending the economic, technical, scientific, social and legal aspects of cluster members;
- Increasing economic competitiveness domestically and internationally through:
 - Supporting a policy of cooperation within the cluster and with other external organizations;
 - Promoting and supporting innovation in structural entities;
 - Developing a common framework for the transfer, valorisation and implementation of advanced know-how;
 - Cooperation between cluster members in research, product development and new technologies;
 - Coordination in defining common strategic objectives: the design and implementation of measures and actions needed to achieve them;
 - Participation in various forms of association and cooperation with other national and international organizations aiming at establishing projects of common interest;
 - Development of activities covered by the nomenclature.

Activities in the European Community (NACE) implemented internally in the National Classification of Economic Activities (NACE - Rev.2):

- a) Implementing activities for the following divisions / groups: ..25/255, 256, 257; ..26/262, 265, 266, 267; ..28/281, 284, 289; ..32/325; ..33/331, 332.
- b) Research - development: NACE division 72/group 721;
- c) Technical testing and analysis activities: NACE division 71/group 712;
- d) Other professional, scientific and technical activities: NACE division 74/groups: 741, 749;
- e) Activities advertising and market research activities: NACE division 73;
- f) Membership organization activities: NACE division 94/group 941;
- g) Publishing activities: NACE Division 58;
- h) Extraterritorial organizations and bodies activities: NACE division 99;
- i) Commerce activities: NACE division 46/groups: 461, 464, 465, 466 and division 47/groups: 471, 474, 477.

The goal of establishing the Regional Cluster MECHATREC is to develop the following strategic technical and technological directions:

- the field of intelligent advanced mechatronic, integronic and adaptronic equipments, multi-structural, technological, and informational features for decision-making, measurement, control, integrative adaptive control;
- the field of high-tech mechatronic systems for industrial and commercial applications;
- the field of intelligent special medical and biomedical devices;
- the field of intelligent and hyper-intelligent mechatronic integronic adaptronic micro-nano-technologies;

- the field of intelligent new materials with micro-nanometric structures and special features new processing technologies and usage;
- the field of innovative and customized modular systems in industry and economy;
- the field of advanced electromechanical mechatronic micro-nano-systems and systems;
- the field of intelligent micro-robotics and nano-robotics;
- the field of intelligent measurement technique, calibration, testing, calibration and functional tests and measurements;
- the field of micro-nano techniques and micro-nano-tribology;
- the field of logistics and support services;
- the field of human resource development and specialization in the field;
- The Regional MECHATREC Cluster structure is based upon economic units and sub-units required to achieve the set objectives and purpose, including:
 - economic production, trade and services – type SME, with or without RDI activities;
 - businesses having as main activity object – Research, Development and Innovation: national institutes, specialized institutes and centres;
 - secondary schools and universities;
 - testing laboratories and specialized testing laboratories;
 - chambers of commerce and industry, operating at central / regional / local level;
 - scientific organizations and professional associations and employers;
 - federations and confederations;
 - regional development agencies;

The Vision of Mechatrec cluster is that by 2020 it becomes one of the most credible service providers of innovative high-tech services and products in Europe and worldwide. The moto of the cluster - "Mechatronics for the future!" – shows the importance of the high-tech field, the training of the human capital in the area of research of excellence and of innovative research, as well as in the very activity of research and development, which is a generator of knowledge, of innovations and of advanced products and technologies that are connected to smart economic growth, but especially the importance of a cluster-like focus, featuring national and international vocation for the development of this innovative field.

MECHATREC is built on the principles and concepts of European structures type "four clover model", which bring together bodies in research, industry and local government.

- The need for forming MECHATREC Cluster is based upon national and European programming documents:

National Reform Plan - Business Environment and Industrial Policy Chapter;

- Mechatronics - Integronics - Adaptronics Development Strategy, as mix integrative scientific field with economically proven potential, but poorly supported at regional level;

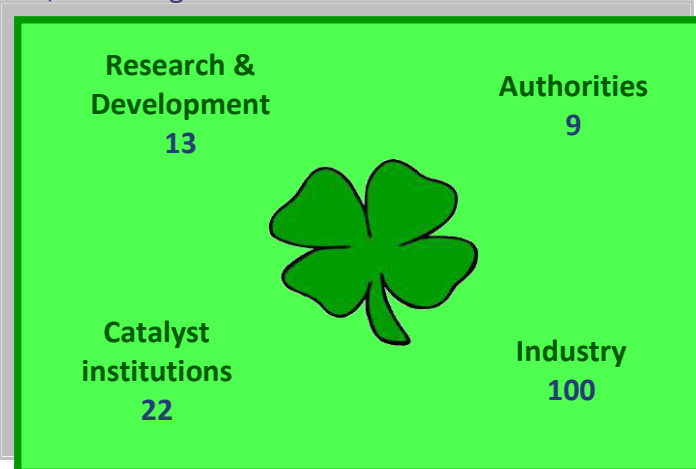

- cluster development program coordinated by MECMA - Romania;
- Europe 2020 and 2030 Strategies;
- Document Cluster Association in Romania, CLUSTERO;
- Documents of the European Cluster Alliance;
- Examples of good practices and successful actions of MECHATREC Cluster:
 - Partnerships with other clusters and competitiveness poles (eg EL - including INDAGRO, ALL ELECTRIC).
 - Collaboration between structural entities (eg INCDMTM - UPB - CCDM - HESPER - CCIB, UMF - Orthopaedics Clinic - Floreasca Emergency Hospital - INCDMTM, INFOSIT - INCDMTM - High School of Mechatronics, etc.)
 - Collaboration with personalities from the field (lectures in the field, supported by: prof. Stiharu Ion, Ph D - Concordia University, Montreal - Canada, Professor. Alexandru Ivan - University Besancon - France Prof Rajshree Mootanah, PhD - University of Oxford England, etc.).
 - Cluster development database (members, designs, manufacturing, etc.).
 - Developing business opportunities between cluster members and joint projects;
 - Amplification and intensification of cooperation between and inter-clusters in high-tech strategic areas;
 - Achievements of mechatronic, integronic and high-tech adaptronic products:
 - **Clusterdevelopment perspective**
 - ✓ Attracting new members;
 - ✓ Membership in the CLUSTERO National Association and the International Alliance of European clusters;
 - ✓ Enhancing partnerships, collaborations and relationships to optimize value chains, products and intelligent manufacturing.



FURTHER INFORMATION:

Professor PhD.EurEng Gh. Ion GHEORGHE

Phone: 021.252.30.68/69, Fax:021.252.34.37, e-mail: geo@cefin.ro ; geocefin@yahoo.com



**THE STRATEGIC COMPETITIVENESS POLE
IN THE FIELD OF MECHATRONICS,
INTEGRONICS & ADAPTRONICS
«INDMECATRON»**

«INDMECATRON»COMPETITIVENESS POLE

Scope of the INDMECATRON Pole:

The scope of the INDMECATRON Pole is to value, develop and implement its own strategies, according to time schedules designed and monitored to achieve the overall and specific objectives:

- Representing, supporting and harmonizing the interests of all economic entities;
- Objective and joint activities projecting, in strategic development areas, developed on the basis of their market research, marketing, valuation, feasibility, technology transfer, and so on,
- Creation, development and commercialization of innovative and intelligent mechatronic and adaptronic products, technologies and services;
- Working on a partnership between the states and the pole and its external entities to promote national and international research - development - innovation projects in common fields based on reciprocity, especially project management and formation of consortia for project development in the value chain matrix of high-tech intelligent mechatronic products;
- Working to address funding for European projects and international tenders and proposals promoting projects of common interest by promoting mutual international consortia formation, able to achieve mutual proposed projects and ensuring their management and coordination;
- Intelligent economical competitiveness through tangible and intangible investments financed from its own resources of national, community, international funds raised, etc.

The Pole specific objectives are listed, as follows:

- Economic competitiveness and national and international visibility techniques and tools:
 - Policies supporting collaboration within the Pole and other entities outside it;
 - Promoting and supporting innovation in all entities in the pole structure;
 - Development of a common framework for the transfer, capitalisation and implementation of advanced know-how;
 - Cooperation among members, research - development - innovation of products, technologies and services for participation in joint projects at national and international R & D programmes;
 - Coordination in defining common strategic objectives: the design and implementation of measures and actions needed to achieve them;
 - Development of new facilities and infrastructure in the new entity or entities within the innovative Pole;
 - International communication networking with other European or international competitiveness poles;
 - Development with public authorities at local, regional, national, and international level, aimed at achieving sustainable development.
- **Good practices:**
 - Forming partnerships based on mutual interest and specialized subfields;
 - Collaboration with other poles of competitiveness;
 - Generation of product / technology and / or high-tech services, developing innovative SMEs in different regions and geographies.

FURTHER INFORMATION: Professor PhD.EurEng Gh. Ion GHEORGHE / Phone: 021.252.30.68/69, e-mail: geo@cefin.ro ; geocefin@yahoo.com



BENCHMARKING NETWORK

BENCHMARKING STUDY CONCERNING TO CAPITALIZATION OF RESEARCH RESULTS FROM INCDMTM ECONOMIC AGENTS OF MECHATRONICS

Program Nucleu nr.pr 16210601

Phase 1 and 2

The project aims as its final stage, through a benchmarking study to develop a mechanism and tools to ensure a better exploitation of research results developed by INCDMTM. SWOT analysis to INCDMTM emphasizes the fact that the Institute has the potential scientific and organizational capacity to develop effective work of capitalizing on technologies/products/services/ knowledge and has a series of specific points of transfer activities: Benchmarking, industrial property, marketing, creating spin-off and start-up.

Overview:

Valorisation results of public research in Firms, represent a problem of major state policies, the rapidity with which to make a transfer of product/technology/process/service and technical performance and economic that such transfer provides them depending and competitiveness of firms that take.

Development companies by the Transfer of results and Innovation, is a concept that we find in all policies developed by the EU. In the last FP5-FP7 programs the problem of transfer results occupying an important place, more accentuated in the current Horizon 2020 Program.

The interest of States for capitalizing result of public research to industry is justified by the fact that from year to year research funding grow (already the EU average exceeded 2% of GDP) and return these funds to the budget must be reflected in the economic effects that bring assimilation of these products / technologies and services in the benefit of society. That is why, Technology Transfer (TT) be the subject of careful analysis in the EU states, in order to find the most appropriate policies, mechanisms and tools to motivate the transfer of knowledge and results, stimulating both the beneficiary of a patent or object transfer as well as also the one to take it over; TT and the last beneficiary, should not be left alone, but need financial support, legislation in this effort. The capitalization of patent and industrial property right there have different ways of treatment in European countries and US, the US practice instituted once the Bayh Doyle law application and validated by favourable economic results being acquired by the Europeans. Granting institution holding patent rights to itself commercialize patent, creating these institutions specialized bodies with TT and having one means that the inventor cannot have boosted activity. Appeared Centre for Technology Transfer in Universities and Institutions, Industry Liaison Offices, Agencies. INCDMTM has a great experience, succeeding previous years transferring research results its economic agents important and has the potential to develop this activity, make this institute a leadership in the promotion of results in research, increasing technical advantages in Institut or the product to which transfer. Technology, service, his experience - concentrated into a guide - can have a high degree of multiplier.

In establishing this guide will be addressed TT mechanisms, instruments should be created to support this activity -atât the patent licensor licensee knowledge and on - barriers that delayed reporting of research valorisation, possible indicators for evaluating the effectiveness, establishing some

solid relations, long-term relationships between the research environment and industry / economic.

Equally, the experience gained in this project and the results may represent a useful contribution to solving a problem of global concern, in the European programs the problem of technology transfer - see ROP program that has a whole division in that finding the problematic - calls finding the most appropriate models for Technology transfer, transfer mechanisms and tools.

Development of innovative high-tech enterprises, result of the innovation process and transfer of research results

Industrial development of the company in the last few decades, more strongly highlighted the importance of innovation and the application of research results. European policies have endeavored to favor innovation by creating a favorable environment conducive to the increasing of labor productivity, economic growth, create jobs and wealth.

Innovation and strong support they formed the basis of creating a huge volume of knowledge, great efforts being made to transfer these results to the industry, lifting its technical level. Increasing sums being spent were allocated from year to year research statistics showing that countries that invest the most in research, benefits the strong industrial development that are based on outcome scientific transfer.

Statistics show explosive growth of innovative SMEs - those companies who use high-tech technology transfers, representing the EU Member economy around 50%, with significant contributions to GDP. There is a high tendency of increasing the percentage of innovative SMEs, those enterprises characterized by sustained policies of assimilation of high-tech products.

Mechatronics through the synthesis of high technology made in various fields, leading to the development of high-tech products intended for leading industries: automotive industry, aerospace, robotics, medical devices industry. This stands out by the high number of companies that address EU27, variety of supply and added value of the products.

In EUROSTAT 2015 appears eloquently the preoccupation of countries to innovation appeal for increasing the number of innovative enterprises. In Table 2 shows proportion of innovative enterprises to EU countries. The European average innovative enterprises of all existing enterprises is 48.9%. Above this average are situated Germany, Ireland, Italy, Sweden, Spain, France, Finland, the Netherlands, Greece; below 25%, there are only three countries: Bulgaria, Poland, Romania.

The proportion of innovative enterprises of all those existing in a country EU-28 is given in Figure 1.

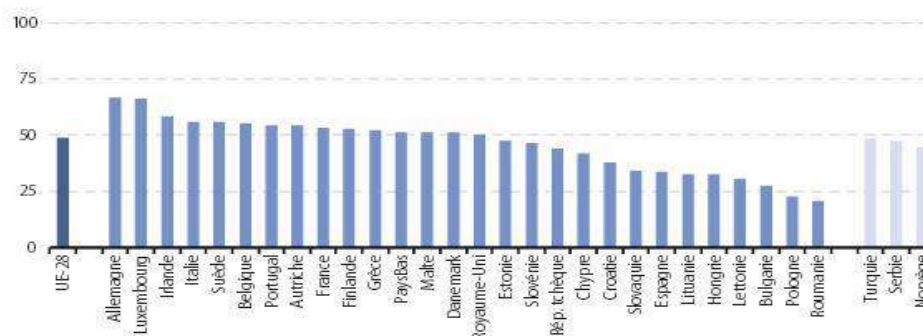

Figure 1. Proportion of innovative enterprises of all those existing in the EU 27

The activity of innovation in a company is not only the assimilation of new products or implementation of new technologies and processes but also to organize activities aimed at enterprise, new ways to do marketing. In

Some important findings resulting from this table:

- The allocation of adequate funds for research explains the economic development of these countries (the first part of the table) compared with countries in the second group of table;
- The industry participate significantly to establishing the fund research compared to the second group, consisting of countries that passed after 1990 to a market economy are not yet consolidated economic to support research, the State is required to take this effort with reduced resources, though granted more as the industry, but funds are insufficient;
- Insufficient financing for research are a cause of transfer less research results together and that the industrial structure of Romania has changed substantially since 1990, with the disappearance of some industrial units strong, new ones - in training and without financial resources - an industry where the largest share of industrial output is achieved in multinational companies who use little to local research results even though they may be competitive as a solution;
- Romania have been identified a number of companies working in Mechatronics, selecting from amongst those who may become potential partners in the development of technological transfers. This selection was made after considering that turnover exceeding 10 million may suggest that the company has some potential financial or human resources to be interested in a possible technology transfer. Since the economic crisis of recent years has collected data and developments that turnover of selected companies made during the years 2006-2014. It noted that data was drawn from official documents sent by companies to the Chambers of Commerce or Chamber of Commerce Bucharest, in their synthesis done by collectively Project;
- From CAEN code analysis, has revealed that Mechatronics is covered mainly by Divisions 26 computers industry, electronic and optical products and optical equipment industry Divisions 27. The paper presents the subdivisions of these Divisions families of products being produced. Benchmarking study done on these divisions provide important data regarding the turnover of the 27 EU countries, value added, salary costs, the type of companies and their contributions to the formation of indicators, labor productivity, employment, the trend of specialization. Comparing the data submitted by Romania to EUROSTAT with the data communicated by with other European countries, made benchmarking analysis suggests the directions of Romania Mechatronics industry through technological transfers can find "niches" that would ensure a competitive participation in international markets.

For the first time in the country will develop a benchmarking study that addresses economic agents and mechatronic profile that will result mainly raising their competitiveness

Also will introduce a new concept in the activities of of economic agents with profile mechatronic namely: commercialization the research results from institute.

Project manager: Dr.ing. Diana Mura Badea

Tel.: +40740113589; E-mail: dianamura@yahoo.com



- “CE–MECATRON” - CENTRE FOR PROFESSIONAL COMPETENCES IN MECHATRONICS EVALUATION
- “CF–MECATRON” CENTRE FOR PROFESSIONAL TRAINING IN MECHATRONICS

“CE–MECATRON”- CENTRE FOR PROFESSIONAL COMPETENCES IN MECHATRONICS EVALUATION

[With National Authorization from CNFPA]

- ➔ Organizes evaluation for:
MECHATRONICS:
 - technician
 - engineer
- ➔ Ensures for the candidates the proper PROFESSIONAL COMPETENCES EVALUATION and the access to their Specific Resources.
- ➔ Issues CERTIFICATES/ DIPLOMAS recognised nationally
 - TARGET GROUP: any person of minimum 18 years of age, with experience in the field
 - REQUIREMENTS FOR THE TARGET GROUP REPRESENTATIVES: graduates from high school with / without high school diploma and / or vocational school graduation diploma

“CF–MECATRON” - CENTRE FOR PROFESSIONAL TRAINING IN MECHATRONICS

[With National Authorization from CNFPA with the following series: BNR-0004768]

- ➔ Organizes training for:
MECHATRONICS:
 - technician
 - engineer
 - ➔ Ensures for the candidates the proper PROFESSIONAL TRAINING and the access to their Specific Resources
 - ➔ The PROFESSIONAL TRAINING courses ensure:
 - ✓ Labour redistribution
 - ✓ Acquiring new skills for:
 - people seeking employment
 - persons employed in the entities and organizations
 - People interested in the labour market
 - ✓ Review of training programs in accordance with the law
 - ➔ The TRAINER course ensures:
 - ✓ Becoming TRAINER, for:
 - persons who have acquired skills of informal trainer (by self-study, at work,, from introductory or short courses) and want official certification
 - persons interested in obtaining the status of qualified Trainer
- Target group requirements: people with higher education or equivalent

FURTHER INFORMATION: Professor PhD.EurEng Gh. Ion GHEORGHE / Phone: 021.252.30.68/69, Fax:021.252.34.37, e-mail: geo@cefin.ro ; geocefin@yahoo.com



**CYBER-MECHATRONICS
RESEARCH LABORATORY**

NEW

EXPERIMENTAL MODEL OF MECHATRONIC AND ADAPTRONIC AND CYBER-MECHATRONIC AND CYBER-ADAPTRONIC SYSTEM

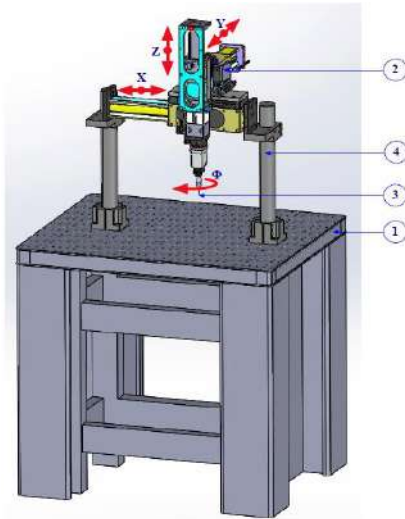

Legend:

- 1 – Anti-vibration table
- 2 – Smart (4D) system
- 3– Smart (ultraprecise) 3D probe
- 4 – Adjustable frame

OVERVIEW:

Within the framework of the Project PN 16210201 "Research on the Design and Making of Virtual and Physical Mechatronic and Adaptronic and Cyber-Mechatronic and Cyber-Adaptronic Models for Laboratory and Industry Work" we have developed an Experimental Model with the following technical features:

- horizontal X axis: made in a structure defined by the nominal stroke (measuring range) of 200 mm and the gauge of the axis of 510 mm, the nominal force of 205 N (and the maximum permissible force of 500 N), 1 linear motor, 1 absolute encoded with high precision and repeatability, 1 controller;
- horizontal Y axis: made in a structure defined by the nominal stroke (measuring range) of 100 mm and the gauge of the axis of 310 mm, the nominal force of 120 N (and the maximum permissible force of 250 N), 1 linear motor, 1 absolute encoded with high precision and repeatability, 1 controller;
- horizontal Z axis: made in a structure defined by the nominal stroke (measuring range) of 100 mm and the gauge of the axis of 100 mm, by the (maximum) nominal force of 115N, 1 linear motor, 1 break, 1 absolute encoded with high precision and repeatability, 1 controller;
- rotating electric axis ϕ with 1 controller, made in a structure defined by: torque: 0.4 / 1.2 (Nm); maximum rotation speed: 600 (1/min.); moment of inertia: 500 (Kgmm²); repeatability accuracy: 0,01 (°); operating pressure: 6 (bar); mass: 1.2 (Kg); temperature: 10/40 (° C); circuit voltage: 530 (V); Current: 1 (A); electronic control: external; encoder system: absolute encoder.
 - “micro gripper” subassembly,
 - “smart (ultraprecise) 3D probe” subassembly.

APPLICABILITY: automotive industry, electronic and mechatronic industry, aerospace industry and so on.

FURTHER INFORMATION: Professor PhD. EurEng D.h.c. Gh. Ion GHEORGHE/ Phone: 021.252.30.68/69, Fax:021.252.34.37, e-mail: geocefin@yahoo.com



**ACCREDITED TESTING
LABORATORIES**

LENGTH TESTING LABORATORY – LIL

OVERVIEW:

The **Length Testing Laboratory** is a laboratory accredited by RENAR according to SR EN ISO/CEI 17025:2005 (accreditation certificate no. LI 783) for the following tests:

- Dimensional and shape errors determination of the limitative plain cylindrical gauges;
- Callipers indication errors determination;
- Micrometers indication errors determination;
- Analogical and digital dial gauges indication errors determination;
- Pneumatic comparators indication errors determination;
- Linear and angular, shape and position dimensional errors determination;
- Vickers hardness test

For these tests, the Length Testing Laboratory uses performing measurement equipments:

TECHNICAL FEATURES:



3D measuring machine with CNC, type LEITZ-REFERENCE 600

Technical features:

- Accuracy: $0,9 + L/350 \mu\text{m}$,
L = measuring length (mm)
- Measurement range X/Y/Z: 1000/700/560 mm
- Resolution: $0.05 \mu\text{m}$

Applications: linear and angular measurements, geometrical tolerances control

Universal measuring microscope with digital display, type STARRETT GALILEO QC-5000

Technical features:

- Accuracy: X,Y : $(1.9 + 5L/1000) \mu\text{m}$;
Z: $(2.5 + 5L/1000) \mu\text{m}$; L = measuring length (mm)
- Measurement range: X/Y/Z: 300 / 150 / 140 mm
- Resolution: $0.1 \mu\text{m}$
- CNC system and VISIO unit

Applications: linear and angular measurements, surfaces positional tolerances control

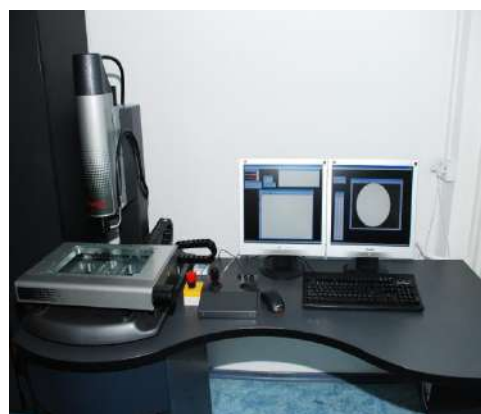

CNC surface and contour tester RONCORDER EC 2500-KOSAKA

Technical features:

- Rotational accuracy:
0,02 μm + 0.0003 $\mu\text{m}/\text{mm}$
- Rotary table with automatic centring
and tilting
- Resolution: 0.001 μm

Applications: control of surfaces form



CNC surface roughness tester IND 120-Taylor Hobson

Technical features:

- Resolution (Z):16nm/1mm;
3 nm/0.2 mm;
- Accuracy X, Z: 0.5 μm

Applications: measurements of surface
roughness and contour

Universal Length Measuring Machine DMS –680

Technical features:

Resolution: 0.1 μm
Accuracy: 0.5 μm
Measurement range: absolute 100mm;
differential: 680 mm

Applications: dimensional and shape
errors determination of the limitative
plain cylindrical gauges, micrometers and
dial gauges indication errors
determination.



MEASUREMENT AND CALIBRATION LASER INTERFEROMETER SYSTEM RENISHAW XL- 80



Technical features:

Linear measurement:

- Resolution: 0.001 μm
- Accuracy : 0.5 ppm
- Linear measurement range: 0-80 m

Flatness:

- Resolution: 0.01 μm
- Accuracy: 0.6% of calculated flatness
- Flatness measurement range: 1.5 mm

Angular measurement:

- Resolution: 0.1 $\mu\text{m}/\text{m}$ (0.01 arc sec.)
- Accuracy: 0.2% of calculated angle
- Angular measurement range: 10

Straightness:

- Resolution: Short range: 0.01 μm ;
Long range: 0.1 μm
- Accuracy:
Short range: 0.5% of displayed value
Long range: 2.5% of displayed value
- Straightness measurement range: 2.5 mm

Squareness:

- Resolution: 0,01 $\mu\text{m}/\text{m}$
- Accuracy: 0.5% of displayed value
- Measurement range: 3/M mm/m, M= measurement distance in meters of the longest axis



Applications: 3D measuring machines and length measuring machines calibration, high level direct measurements

OPTIMAR 100 Test Instrument

Technical features:

- Resolution: 0.02 μm
- Accuracy: 0.2 + L/100 μm ; L = measuring length (mm)
- Measurement range: 100 mm

Applications: dial gauges and inductive probes calibration



Height Gauge MICRO-HITE 350

Technical features:

- Resolution: 1 μm
- Accuracy: $2 + 3 L/1000 \mu\text{m}$
- Measurement range: 350 mm

Applications: dimensional errors determination for terminal sizes, height and length calibers and standards



Hardness Tester 251VRS-AFFRI

Technical features:

- Resolution: 0.1 HV-HB-HR
- Digital display
- Automatic conversion different scales: Rockwell, Brinell, Vickers

Applications: Rockwell, Brinell, Vickers hardness measurement

CAPITALIZATION AND TECHNOLOGICAL TRANSFER:

- Measurements within some research projects or on contract basis with beneficiaries from the automotive industry, aeronautics, etc.

BENEFICIARIES:

- SC Autochassis International
- SC Automobile Dacia
- SC Renault Mecanique Roumanie
- Research institutes and universities laboratories
- SC Gruppo Italiano Imballage SRL
- SC Plastic Legno Romania SRL

FURTHER INFORMATION:

Eng. Henriette Arabagian, chief of the Length Testing Laboratory -LIL ;

Phone:: 021-252.30.68/331, 323; E-mail: laborator_tm1@yahoo.com

PRESSURES TEMPERATURES CALIBRATION LABORATORY LE-PRESSURES



OVERVIEW:

Calibration laboratory - LE 009 operates under the legal responsibility of INCDMTM- Bucharest, organized as a National Research & Development Institute, internationally accredited with «A+». As part of INCDMTM - Bucharest, LE was founded in 1990 as a "Testing Laboratory, in the field of testing and metrological metering of pressure, temperature, becoming in 2012 the «Pressures, Temperatures» Calibration Laboratory. The field of activity of the Calibration Laboratory – LE is relative pressure measurement of fluids and gases.

TECHNICAL AND FUNCTIONAL CHARACTERISTICS:

Objectives:

- Calibration Laboratory - LE is responsible for maintaining traceability standards of equipment by regular calibrations relative to standards of other national and international institutes on metrology: INM- Bucharest and / or FINAS. Accredited by ilac-MRA;
- Management, maintenance, development, preservation, conservation and maintenance of standards and of the measuring endowment of the laboratory;
- Participation in interlaboratory comparison schemes with the purpose of maintaining the measurement capability of the laboratory;
- Maintaining and continuous improvement of the Quality Management System in laboratory.

Principles of Calibration Laboratory - LE:

- Independence – the staff of the laboratory is not subject to any internal or external pressure in terms of taking decisions on calibrations results;
- Trust – technical competence, growth of the competitiveness of the personnel, integrity of the laboratory is only few targets for winning and maintaining trust;
- Privacy – application of policies and procedures in accordance with the Quality Management System implemented within the laboratory, which ensures protection of information and property rights of clients;
- Responsibility – awareness of the personnel on the importance calibration activity and insurance of a qualities the best of these services;

- Quality - development, implementation, maintenance and improving of the effectiveness of the quality system.

APPLICABILITY AREAS :

Calibration Laboratory - LE in the field of pressure measurements is Accredited by RENAR with the Accreditation Certificate No: LE-009 of 05.02.2013, in accordance with EN ISO / IEC 17025: 2005 and is competent to perform calibration activities in accordance with the Annexes to the certificate, updated on 04/07/2013 by RENAR through the Accreditation certificate no. 009 / 1.1 LE.

Measurement capabilities: Calibration Laboratory - LE can perform calibrations permanently, at the premises, according to the Accreditation certificate no. n No: 009 / LE 1.1 from 07/04/2013

CAPITALIZATION AND TECHNOLOGY TRANSFER:

Calibration Laboratory - LE provides services in the following measurement intervals accredited for the measured size - relative pressure:

1. Transducers and Pressure transmission with voltage or current output;
2. Manometers, vacuum gage and vacuum metre with indication analogue or Digital.

The staff in the calibration laboratory - LE deals with the execution of calibrations and will not, under any circumstances, perform specific serve activities to the devices handed over for performing calibration.

The equipment in the laboratory are operated by the management personnel and by the technical personnel with high expertise. The instructions for use and maintenance of equipment (including user manuals of the manufacturer) are available in the laboratory for use by the staff of the laboratory.

The calibration certificates issued by calibration Laboratory – LE are according to EN ISO / IEC 17025: 2005 and meet all applicable standards and requirements of the Accreditation Association RENAR.

In the calibration process are used updated documents such as:

- RENAR policies;
- EA Documents - European Co-operation for Accreditation;
- EURAMET Documents - European Association of National Metrology Institute;
- ISO Documents - International Organization for Standardization;
- Documents according to the Quality Management System implemented by the Laboratory.

BENEFICIARIES: Calibration Laboratory – LE are oriented to all the beneficiaries in Romania and abroad who have the means to measure the pressure

FURTHER INFORMATIONS: Eng. Valentina Bajenaru, PhD , E-mail: incdmtm@incdmtm.ro / valibajenaru@yahoo.com



RESEARCH-INNOVATION LABORATORIES

OPERATING UNDER INTELIGENT MEASUREMENT MECHATRONICS COMPARTMENT

LABORATORY OF INTEGRATED CONTROL MECHATRONIC SYSTEMS

ACTIVITY FIELD

Founded together with the Institute, this compartment has carried out thousands of research and development works for our major beneficiaries consisting in a wide range of products, from the simplest of them (gauges, mechanical devices, pneumatic buffers and rings and so on) to the most complex of them (tightness checking machines, tappet selecting machine, machine for pressing spindle to the tappet lever etc.).

The laboratory benefits from the modern calculus technique and specialized design software tools. The specialists of the laboratory have participated and participate continuously to the rising of the level of training by attending training courses.

We are a leading supplier of plants, machinery, equipment and unique devices for controlling the auto parts for Dacia Groupe Renault cars.

By capitalizing the results of research together with the other laboratories of the Institute (Laboratories MMI4, MMI3 and MMI2) and in collaboration with renowned companies (Festo, ATEQ, Siemens, Bosch, Parker, Mitutoyo, Mahr, Tesa, Tox-Pressotechnic etc.) we managed the development of both domestically and internationally competitive works.

Some of our achievements were exhibited in national and international Exhibitions and awarded various prizes and recognitions.

Sphere of activity:

- 1) Research projects under national and international programs
- 2) On demand design:
 - √ Mechanical and electronic dimensional control devices
 - √ Machines, equipment and computing devices for dimensional control
 - √ Installations, equipment, pneumatic parts for dimensional control
 - √ Machines and equipment for checking tightness
 - √ Machines, installations and mounting devices
 - √ T-NT gages
- 3) Technical Studies
- 4) Control Technologies

PRECISION MEASUREMENTS AND SMART CONTROL LABORATORY

FIELD OF ACTIVITY:

In accordance with the provisions contained in the Science and Technology thematic areas (according to FP7) in the Draft of the Decision of the European Commission on FP7 - EC COM (2005) 119 final:

1. Activities of applied research and precompetitive development, dissemination, technology transfer and capitalization of research findings
 - 3.1.3 Embedded systems, computing and control
 - 3.1.4 Software, network security and interdependence
 - 3.2.4 Smart infrastructures following the development of infrastructures that are more efficient, more robust in everyday use and resistant to failure
 - Mobility 3.3.1: intelligent transportation systems and vehicles; safe, comfortable and efficient transportation of people and goods
 - 3.3.3 Fabrication: rapid and adaptive design; production and delivery of goods with high adaptation to customer requirements; digital and virtual production; modelling, simulation, presentation, miniaturized and integrated products
 - 4.3 New productions
 - 4.4 Integration of technologies for industrial applications integrating new knowledge and technologies, nanomaterials and production processes and cross-sectoral applications
 - 6.1 Environment and health
 - 7.2 safety and security in transport

PRODUCTS:

- Control equipment for deviations of form and position
- Equipment for controlling gears
- Equipment for active control
- Roughness control devices
- Profile projectors
- Instruments for measuring profiles
- Machine for tool presetting
- Instruments and equipment for inspection of auto-mechanical, electronized / informatized parts:
 - √ complex installations for torque control, pressure and crankshaft clearance
 - √ computing systems with axle gearbox control
 - √ installation for collector verification
 - √ control equipment for pinion blows to the gearbox
 - √ noise control equipment
 - √ control for fork devices
 - √ disc brake control devices
 - √ hub control device
- Machinery and devices for threads control
- Devices for automatic measurement and sorting.

COMPLEX SYSTEMS AND AUTOMATION CONTROL LABORATORY

ACTIVITY FIELD

1. Basic and applied research activities on:

► Measurement and dimensional control systems:

- Equipment for measuring non-contact probes using optical, laser and ultrasound tools
- 3D measuring techniques and systems
- Automatic movement and spatial positioning for measuring complex profiles
- Miniaturized probing systems
- Equipment for laser flow control

► Automatic control and command systems:

- Specific control systems for image acquisition in precision mechanics, electronics, medicine, biology and biotechnology
- Metallographic determination system for materials' microstructure
- Computerized analysis systems of the *in vitro* development vegetal hybrids
- "Embedded" systems for on demand themes
- Error prevention techniques and systems for complex fabrication processes

2. Activities of design, commissioning, technical assistance, consulting for the automotive industry:

- Dynamic cabinets for assisting operators on assembly lines
- Automation systems for assembly and control posts

Products:

- Portable devices for determining electrical charges of surfaces
- Portable devices for barcode acquisitions
- Dynamic cabinet systems for rapid identification of marks
- On demand Automation Systems with proprietary PLC, or PLC developed by: Siemens, Moeller, Schneider
- Control systems for stepper motors
- Electronic systems equipped with Atmel microcontrollers
- Small portal Coordinate Measuring Machines
- Laser equipment and computer system for the certification of final measures
- Equipment for computer analysis using video-electronical feeling
- Discrete feelers with switches, optical feelers
- Electronic rotary tables, dividing heads with digital display and interface for PC
- Dividing heads with transducer, digital display and interface for PC.

ENVIRONMENTAL ENGINEERING SYSTEMS AND RENEWABLE ENERGY LABORATORY

In this laboratory, we have developed several innovative systems:

System of diagnostics passenger wagons: The diagnosis system is a computerized system, redundant, aiming to detect a defect, the place where it occurs, the way it can be eliminated and how to memorize the event.

Organic airtight vacuum toilets for passenger cars – Ecotoaleta: The vacuum toilet system is a compact, automated, low water consumption and based on an electro-pneumatic system, which meets the requirements in passenger trains using European standards on hygiene and environmental protection.

System of specific investigations on tough composite materials: The system on investigation of hard metal powders is made for physical measurements of particulates, which directly influences the quality of finished products obtained by sintering.

Alcohol meter: The alcohol meter is a device for determining alcohol production and is part of the flow meter drum category that makes direct measurement of fluid flow and discontinuity.

Flow meter with digital display for stands for testing hydraulic pumps: The meter uses a variable time base and a turbine flow transducer, which allows the use of six variants depending on the measuring range.

Thermal mass flow meter: Thermal mass flow meter measures the flow of industrial gases based on the principle of hot wire anemometry.

V-Cone Flow Meter for industrial liquids: The device is part of flowmeters with constant section measuring, no moving parts, which measure the indirect flow of industrial liquids.

Transmission system unit based on GPS signal - MASTER CLOCK: The master clock displays the universal time information (hour, minute, second) or date (day, month, year) and allows local time to be compared to the Universal Time (Greenwich).

Litermeter: The Litermeter is a system of measuring the fuel consumption of trucks and buses equipped with diesel engines.

Command and control system of heat treatment furnaces: The product is a system of command and control program with temperatures in small capacity electric furnaces for heat treatment laboratories.

Portable tachometer: The tachometer is an opto-electronic device with non-contact measurement whose operating principle is generating a light spot projected on the direction of a reflector (brand) mounted on the rotating part.

Transmitter for measurement and control: The transmitter is a unified signal device based on galvanic separation, dedicated for measurement and control appliances from domestic production in order to increase automation of measurement processes.

Simple door intercom for passenger wagons: Simple doors and intercommunication doors are electro-pneumatic systems that drive the doors of the cars of passenger wagons.

SMART TERMOTECHNICAL MEASUREMENTS LABORATORY

Field of activity:

- research on systems, equipment, methods and technologies in the field of measurement pressures, temperatures and level;
- advanced research and applied research permanently connected to requirements of the Internal Market and European and international trends in the field;
- development and integrated approach for making use of sustainable directions of new research and related activities in the field of water resources;
- analysis and synthesis of the factors having effect on the competitiveness, effectiveness and performance, and superiority of SMEs on their competition market;
- developing strategies aimed at improving output performance, increasing efficiency, providing a high quality of service based on benchmarking;
- studies, analyses and forecasts;
- performing research and developing applied innovation technologies, that has both a technical / economic viable point of view as well as an environmentally friendly one;
- organizing, supervising and performing demonstrative projects and pilot projects to promote the above technologies;
- implementing research results into commercial projects in the private sector and those of local authorities, professional associations, etc.;
- offering services and technical consulting in the form of specialized know-how and information for third parties;
- experiments, testing equipment and systems in the field;
- offering advice in the areas of pressure, temperature, level and in the national policy, strategy and planning of these fields;
- disseminating the results of research in the field of expertise and offering viable information meant for supporting the interested investors interested and organizations;
- organizing and / or participating in technical and scientific seminars, educational programmes, specialized training, meetings and so on;
- attracting and preparing of workforce using the newest technologies of simulations to educate technicians quickly, which would allow for practice in secure environments and would ensure reduction of errors;
- participating in scientific and technological clusters, competitiveness poles and excellence virtual knowledge platforms, eco-innovation platforms;
- participating and elaborating in research-development projects and in national or European programmes as a coordinator and / or a partner.

Research infrastructure

• Autonomous modular system for monitoring atmospheric conditions

(Intell. IRS31 Road sensor; VS20-UMB Visibility sensor; UMB ISOCON converter; Schneehohensensor SHM30; Luftdrucksensor air press. P; UMB Analog transmitter; Netzteil / net adapter 24V / 4A Surge arrester; Überspannungsschutz VENTUS; Visibility calibration kit);

• Noise measurement system and accessories

(Source; Amp; Sonometer; Plate Tone Soft Dirac, Cable Sound triaxial lemo 3.5 mm jack connector 3m cable from your sound card type in 2239; cable connecting plate-amplifier Tripod for. Source; Tripod for. Sonometer; box for. transport and storage);

- TOSHIBA TLP-X-200 Projector;
- 3 / PD1 BEIRFELD Gauges;
- MMV Gauge type 250; (MMV compensated)
- BUDENBERG gauge; (70bar);
- M2200 Gauge with piston and heights, model: BL2H 1200, measuring range (1 ... 1200) bar;
- Pressure calibrator kit type PC6-0700-CH; + Sical Soft (SI pressure);
- Temperature calibrator with dry bulk (-50 + 150) °C with Kit Quartz accessories (GIUSANI);
- PTX 620 Pomp of vacuum / pressure; 1,6bar abs .;
- Tektronix oscilloscope;
- Pressure transmitter (0 ... 20) bar abs. D10 type, with EasyCom and EasyCut Light software and RS323 cable and serial-USB converter (with digital output);
- DPI TIP-800 Pressure calibrator (GE Druck);
- Set of 6 digital pressure gauges;
- Set of 7 pressure transducers;
- FLUKE 8846A Digital multimeter;
- 603 TLP source of DC (0-30 V; 0-5 A; 60-60 V; 0-3A);
- Power source 115, 230Vac, output: 2x24x10,3A, 1x12V10 A PS3010;
- Set of transducers for pressure and temperature, with display
- RML6 LAUDA liquid thermostat;
- Vacuum pump (KNF type ANDC 24V N 828);
- Thermohygrographic;
- Stopwatch;
- Data acquisition NI USB-6210, code 779675-01;
- Desktop PC, Laptop, Windows 7.10; Office; Professional SolidWorks 2015, SolidWorks; Simulation Professional 2015; AutoCAD LT 2006 Commercial, Labview PDS, En, Windows; printers; scanner.



Results

Analyses, studies, new products, methods, technologies, experimentation, systems, equipment and robots in the areas of laboratory, strategies, methods of applied benchmarking, IT applications, projects in the field of technology transfer, articles, papers presented at scientific events, organizing and participating in workshops, scientific events.

Projects

1. Advanced pneumatic systems for robotic actuating and other industrial applications based on the development of new types of proportional mechatronic servodistributors
2. Creating a benchmarking network aiming at using strategic benchmarking, performance and process benchmarking aiming to complement the economic reform, and to enhance commerce for small and medium enterprises / BENCHMARK
3. Development of IT platforms for characterizing the potential of the field of precision mechanics, mechatronics, automation, and optimization in order to increase competitiveness of specific activities - developing a collaborative environment / IPCPMMA
4. The use of smart grids for on-line monitoring of the quality of electrical networks
5. Compared analysis of law and financial institutions and instruments for the evaluation of transfer and exploitation of results
6. GRID-BENCHMARKING resource centre for analysis, evaluation, processing data, in order to increase competitiveness of organizations to achieve high performance / GRID - BENCHMARK
7. Smart autonomous mechatronic equipment for the disposal of deposits of snow on secondary driveways in the urban environment / UACUZ
8. Prospective study on the implementation of Benchmarking in Romania / ST BR
9. Development capacity to keep the transfer and commercialization of research results in institutes and research centres applied to the ROMANIA - implement a pilot model for specialized departments
10. Wide network of sensors for water use - WIDSENS. Technology transfer to SMEs - FP7 Program
11. NUCLEU Programme: Benchmarking study on the exploitation of research results of INCDMTM in the businesses of mechatronics
12. Technology transfer and assistance for the implementation of research findings in the area of replacement of CFC coolants with cooling ecological use of laser cutting machines
13. NUCLEU Programme: Study on intelligent systems for measuring thermo-technical parameters in residential buildings
14. NUCLEU Programme: Support-study for defining the national strategy in the production of mechatronics equipment for measurement, control, pressure and temperature control

15. NUCLEU Programme: System m of hall sensors measuring the fluid level
16. NUCLEU Programme: Methods and systems for high precision measurement and control of the level of technical fluids
17. Technological methods and procedures for the realization of sound absorbing and soundproof areas for protection of populated areas against the noise produced by trucks on highways
18. Autonomous modular system for monitoring of atmospheric conditions on inland road transport (temperature, barometric pressure, fog, ice, snow, wind, precipitations)

Services offered in the fields of activity

- fundamental research;
- research for gaining new knowledge and competences for developing new products, processes or services or for a significant improvement in existing products, process or services, development of laboratory prototypes;
- development of new or improved products, processes and services, defining, planning and conceptual documentation of new products, processed and services;
- prototyping, demonstration, creating pilot projects for testing and validation of new or improved products, processes or services in environments representative for real functioning conditions;
- transmission of information, experience and best practices, as well as cooperation for promoting innovation;
- implementation of a new or substantially improved in practice of the product, service or process;
- placing a new or substantially improved product or service in the economic cycle;
- dissemination of information, providing consultancy, transmission of knowledge acquisition of specific devices and equipment in order to introduce to the economic cycle the results of research, converted into commercial products and services;
- exploitation of research results.

Perspectives

- excellence research in order to obtain advanced scientific and technological results;
- integration in national and European / international networks;
- national and international research proposals financed from private and / or public funding;
- approach and development of other directions and advanced themes;
- realization of transfer technological of the results of research in the economic environment;
- development of the advanced field of increase of energy efficiency by smart management of the building;
- development of the advanced field of water resources;
- development of the high-tech field of interactive IT products for the protection of the environment and of non-conventional energies;
- development of the smart field of promoting renewable energy resources;
- strategy for the Danube region;
- Parametrized diagnosis, environmental parameters monitoring: water, air and soil;

FURTHER INFORMATIONS:

Eng. Dumitru VLAD, PhD, Phone +40212523068; e-mail: didivlad2006@yahoo.com

OPERATING UNDER BIOMEDICAL MECAHTRONICS AND ROBOTICS COMPARTMENT

BIOLAB LABORATORY

Overall objective

The overall objective of BIOLAB is the contribution to growth of economic competitiveness on the medium and long term by increasing the quality and efficiency of the activities of research - development of national institutes, which will ensure efficient services for units of public health by equipping with modern tools, rehabilitation software and the creation of new modern research laboratories.

BIOLAB will support the integration of research - development – innovation in INCDMTM Bucharest, in the field of biomechatronics, in an economic innovative, knowledge-based activity which is emerging in the Development Region of Bucharest-Ilfov and in the European research area (ERA).

Specific objectives

BIOLAB has the following specific objectives:

- ▶ increasing the capacity of research - development – innovation of INCDMTM Bucharest by developing the infrastructures and attracting young and highly qualified specialists;
- ▶ strengthening of knowledge supply and service of medical research done by the beneficiary - a research institute;
- ▶ stimulate technology transfer based on the cooperation between the institute and R&D companies;
- ▶ stimulation of innovation demand of enterprises;
- ▶ supporting training and development of high-tech companies.

BIOLAB Presentation

BIOLAB is located in the building of the National Institute of Research Development in Mechatronics and Measurement Technique (INCDMTM), at the 4th floor.

BIOLAB includes:

1. Software and hardware for 3D reconstruction of medical images and CT design.
2. Mechatronic equipment for advanced technologies of selective laser sintering.
3. High-tech equipment for testing and controlling of complex biomechatronic systems under stress in conditions similar to those in vivo.
4. System analysis and simulation work.

LABORATORY OF SMART SYSTEMS. DATA ACQUISITION AND ROBOTICS

Activity Field

The laboratory is focused on the research and development of aims to research and development of robotic systems with non-industrial applications: inspection robots, investigation robots, intervention robots, sampling robots, robotic systems with serial parallel or mixed kinematics, with virtual applications in medicine.

Another activity of MBR 2 is the building of LabVIEW applications in data acquisition from various sensors (temperature, humidity, acceleration, etc.), processing and interpretation.

Features

1. Specialized data acquisition equipment, including computer system, National Instruments 6035 data acquisition plate, LabVIEW 6i Base Package Software, with the following characteristics:
 - 16 analogue inputs
 - Sampling rate: 200 000 samples / sec.
 - ADC resolution: 16 bits
2. Motion control equipment, which includes computer system, NI PCI-7356 motion control board, UMI-7774 and UMI-7772 motor control interfaces, LabVIEW Full Development System 8.2 software, with the following characteristics:
 - 6-axis motion
 - Each axis can be configured for step-by-step or servo command
 - Windows XP
 - Compatible software: Visual Basic, C, C ++
 - Recommended software: LabVIEW
 - Driver software (included): NI-Motion
 - Interface for 4 axes
3. Calculation system + software for computer aided design - SolidWorks PREMIUM OFFICE 2008
4. Data Acquisition Plate "High - Performance Multifunction DAQ for USB M Series 16-Bit, 16 Analog Inputs - NI 6229", 2 pieces:
 - Analog Inputs: 16
 - Resolution: 16 bits
 - Sampling rate: 250 000 samples / sec.
 - Analog outputs: 4
 - Analog outputs Resolution: 16 bits
 - Sampling rate analogue outputs: 833 000 samples / sec.
 - Category: ± 10 V
 - Digital I / O: 48
 - Operating system: Windows Vista, XP, 2000
 - Recommended Software: LabVIEW

5. Control equipment for robotic system, including:

- Customer Platform with NI PXI power supply-1031
- Industrial Computer NI PXI - 8106
- Motion Controller NI PXI -7356 6-Axes, with the following characteristics:
 - 6-axis motion
 - Step-by-step or servo command configurable for each axis
 - Compatible software: LabVIEW, Visual Basic, C, C ++
 - PID cycle period: 62.5 to 500 ms / cycle
 - Servo control of output voltage: ± 10 V, 16-bit (0.000305 V / LSB)
 - Analogue outputs: resolution 8, 16-bit, ± 10 V DC
- Control interface UMI-7764, with the following characteristics:
 - Interface for 4 axes
 - Isolation of signals
 - 24 VI / O
- Professional Development System LabVIEW 8.6 software

ECHIPAMENT MECATRONIC PENTRU TEHNOLOGII AVANSATE DE SINTERIZARE SELECTIVĂ CU LASER



LABORATORY INVESTIGATION MICROSYSTEMS, BIOSENSORS AND BIOMATERIALS

Field of activity

The laboratory addresses a wide range of new medical devices designed to highlight the new clinical methods used by medical research facilities in the country.

The areas of competence of the laboratory are:

- Equipment for dental offices and technical dental laboratories;
- Equipment and instruments for implantology and dental reconstruction;
- Prosthetic elements for orthopaedics and traumatology;
- Tool kits for orthopaedic surgery;
- Devices for intensive therapy (infusiomates and injectiomates);
- Braces and spacers for general surgery;
- Tool kits for ophthalmologic surgery;
- Equipment and instruments for surgery laparoscopic;
- Laboratory devices;
- Devices for automatic distribution of drug solutions;
- Developing automatic equipment and imagistic devices doe radiographs embedded in low radiation radiological devices;
- Modernization of the radiology equipment existing in hospitals with the view to reducing the level of the radiation dose to that allowed by international regulations;
- Tensile tests for medical devices;
- Rehabilitation and service for medical devices (operation note no. 145/14.11.2003 issued by the ministry of health and family on the importation, storage, manufacturing, repair, verification and commissioning).

Some of the medical devices made commonly include:

- Cautery devices;
- Surgical instruments;
- Cable monitors, cautery monitors, etc.;
- Instruments for laparoscopic surgery;
- Control and auctioning elements for medical devices;
- Blood pressure measuring devices;
- Patient plates;
- Refurbishment of scissors, drills and tweezers;
- Needle support;
- Controlled infusion devices;
- Instruments for orthopaedics;
- Secretion vacuums;
- Driving pedals;
- EKG monitors.

RAPID PROTOTYPING LABORATORY



Presentation

The Rapid Prototyping Laboratory is unique in Romania. It is based on the technique "high-tech laser sintering for metal powder" that works on the principle of obtaining parts from sintered metal powders (local molten solidified materials) using a laser beam.

Complex geometries can be addressed by creating parts directly in 3D software of the installation -CAD systems, allowing their implementation by adding successive layers of powder (with a thickness of about 18 microns), which are then sintered.

This is a modeling process used in producing parts with high accuracy and high resolution and with good surface quality and mechanical properties similar to those obtained by applying conventional casting processes.

Services

- manufacturing of models and prototypes for implantable biomedical products;
- manufacturing of functional prototypes for the automotive and aerospace applications;
- making molds of high quality and durability.

LRP strategy

- Design, manufacture and testing of static and dynamic options of implants and other mechanical parts for the automotive and aeronautics applications;
- Execution of functional prototypes for the industry, along with molds, individual components, customized parts, biomedical and biocompatible implantable devices;
- Involvement in international strategies, under the EU and national scientific research areas, technological and innovation development through participation in partnership-based projects aimed at attracting structural funds.

OPERATING UNDER MECHATRONIC MICRO – AND NANO - TECHNOLOGIES COMPARTMENT

PROCESS MICRO AND NANOTECHNOLOGIES LABORATORY

Field of activity

- Engineering of systems and micro-systems of conventional and non-conventional processing: Analysis and diagnosis of process; Dedicated technological logistics developed in computerized systems / micro-systems for computerized processing, monitoring, management and transfer; Equipment/systems for checking and testing the process and the end of the technological process; Approaches to the processing, industrial applications, laser
- New materials: Research applications of composite materials with nano structures / micrometre; Research for processing technologies and use of new materials with special characteristics; Methods and equipment for investigation, characterization and processing new materials investigated;
- Nanotechnologies: Studies and analyses of evaluating the potential uptake of new research areas such as micro- and nano-dimensions and micro- and nano-structure; Forecasting immediate and future directions on the development of micro and nano-mechatronic systems, and especially micro- / nano-sensors and micro- / nano-actuators; Development of specific methods and procedures for characterization and evaluation.
- Forecast studies, strategies: Market studies; Sectoral development strategies; Forecasts on sector development.
- Studies / analyses of frictional systems: Analysis of specific tribo-systems for chipping and micro-chipping of metallic and non-metallic materials using hard and super hard composite structures; Study of the effects induced to the tribo-system by varying technological parameters according to categories of processes; Developing methods and testing procedures complementary to those practiced in the EU; Structural and operational characterization of wear-resistant coatings.

In the compartment, there is the Centre of Excellence called "Logistics and transfer for hard and super hard materials ", which operates as a network of scientific connections bringing together specialists from INCDMTM, institutions of higher learning, research institutes and private companies in the field of research.

The main strategic directions deriving from preliminary strategic directions include: The formation of a multidisciplinary extended core, with a higher potential of elaboration, promoting and developing sustainable projects that are also compatible with current requirements of internal and external market research; Development of a material base for research aligned to the scientific European and international requirements; Further development of associative activities, partnership with internal and external research entities, respectively, SMEs with innovative vocation and appetite for research and development.

CERTIM LABORATORY

Overall objective

CERTIM's overall objective is to contribute to increasing levels of economic competitiveness by increasing the quality and efficiency of activities of research – development in research institutes and SMEs will ensure efficient services for businesses by equipping with modern equipment, tools, software and the creation of new and modern research laboratories. CERTIM will support the integration of research, development and innovation of INCDMTM Bucharest for the smart laser-based measurement as an innovative economic activity, based on knowledge and intelligent techniques in the Region of Development Bucharest - Ilfov and in the European research area (ERA).

CERTIM has the following specific objectives:

- ▶ increasing the capacity of research - development – innovation of INCDMTM Bucharest by developing the infrastructures and attracting young and highly qualified specialists;
- ▶ strengthening of knowledge supply and service of medical research done by the beneficiary – a research institute;
- ▶ stimulate technology transfer based on the cooperation between the institute and R&D companies;
- ▶ stimulation of innovation demand of enterprises;
- ▶ supporting training and development of high-tech companies.

Scope of services:

- ▶ In metrological and industrial laboratories;
- ▶ In technical and technological manufacturing;
- ▶ In other specialized and related fields.

2015 Bucharest, Romania

CERTIM Overview

CERTIM is located in the building of the National Institute of Research Development in Mechatronics and Measurement Technique (INCDMTM) as a clean room space. CERTIM contains four operational laboratories:

- LABORATORY OF NANOMETROLOGY;
- LABORATORY OF COMPLEX MEASUREMENT AND POSITIONING;
- LABORATORY OF ULTRA-FAST LASER MEASUREMENT;

● LABORATORY FOR ADDITIVE PROCESSING AND PROMOTION.

Technical characteristics of the cleanroom:

Standard: ISO 14644 (USA- FS-209 D)

Class 10000 - ISO7

Useable Space: 59 m².

Environment conditions:

- humidity (%): 45 ± 10 ;
- relative pressure, Pa: 25 ± 5 , between the clean room and outdoor;
- temperature ° C: 20 ± 1 OC
- speed air circulation; in accordance with the parameters of standard class clean room, but no less than 0.25 m / s.
- noise level - $42\text{dB} \pm 3\text{dB}$.
- lighting: light boxes, in accordance with the parameters of standard class clean room (500 W)
- emergency lighting for escape autonomous systems (one hour of autonomy).





NGO's



PROFESSIONAL ASSOCIATION OF THE ROMANIAN PATRONATE OF PRECISION MECHANICS, OPTICS AND MECHATRONICS – APROMECA

OVERVIEW:

APROMECA is a professional association, a non-governmental, a-political and non-profit organization made up of registered juridical and authorized physical persons activating in the field of Precision Mechanics, Optics and Mechatronics. The association reunites **20 affiliated members**: RDI national institutes/RDI institutes, SROMECA Association – The Romanian Mechatronics Society as well as economical agents/producers (SMEs).

<ul style="list-style-type: none"> • INCDMTM - Bucharest • The National Institute for Research and Development in Electrical Engineering ICPE – CA • THE RESEARCH INSTITUTE FOR HIDRAULICS AND PNEUMATICS INOE 2000 – IHP Bucharest • THE ROMANIAN ECONOMICAL AND SOCIAL STUDIES – IRECSO – Bucharest • UPB – RESEARCH AND DEVELOPMENT CENTER FOR MECHATRONICS – CCDM • SC. PRO OPTICA SA Bucharest • SC. OPTOELECTRONICA 2001 SA Bucharest • SC. ITM – AMIRO SA Bucharest • SC. ROMFLUID SA Bucharest • SC. CARMESIN SA Bucharest • SC. CONTOR GROUP SA Arad • SC. BADO THERM AMC SA Vaslui • The Romanian Mechatronics Society – SROMECA • SC. TEHNOROM Bucharest 1990 SRL • C.I.T. Automations • SC. QUATRO PROD COM SRL Bucharest • SC. GENERAL FLUID SA Bucharest • SC. HESPER SA Bucharest • Etc . 	<p><i>APROMECA unfolds the following activities:</i></p> <ul style="list-style-type: none"> ➤ industrial marketing; ➤ information exchange and access on the evolution of the activity field at an international scale; ➤ promotional activities; ➤ Intercessions on the training of specialized experts ; ➤ specialized Exhibitions and exhibitions both in Romania and outside the country; ➤ European qualification actions, inclusively the harmonization of the Romanian legislation to the normative dispositions of the European Union; ➤ representing the members in the social dialogue without affecting their independence; negotiating and enclosing the collective work contract in the branch, participating in other agreements with the public authorities and the syndicates, as well as participating in management and social dialogue; ➤ forwarding to the proper Public Authorities in charge of proposals for laws; <p><i>Accessing financing as subventions, donations, subscriptions, contributions, sponsorships.</i></p>
---	--

APPLICABILITY:

Promoting research, development, innovation, marketing and knowledge dissemination activities in the field of mechatronics, advanced micro- and nano-processing micro-technologies in the field of mechatronics, micro-technologies.

TECHNOLOGICAL TRANSFER:

Capitalizing the applicative researches in the fields of precision mechanics, optics, mechatronics are found in the profile SMEs productions, as: technological and production systems, remote-control systems, bio-medical systems, slate and tools made of c.m.s, instrumental tools used in implanthology, cold, hot and branch-type meters, opto-electronic equipments for industrial applications, medical and military applications as well as micro-optical and nano-optical technologies.



Advanced micro-technology and equipment for micro- and nano-processings with laser beam by sintering - INCDMTM



Robotic module 3 DOF
UPB-CCDM Bucharest
robotic cu 3 DO



Cold and hot meters, of
branch-type Contour
Group Arad



Pressure differential transducers
INOE 2000 - IHP Bucharest



BENEFICIARY:

SMEs in the field of precision mechanics, optics, mechatronics, micro-optical and nano-optical measuring and control measuring technologies.



**SCIENTIFIC
PRODUCTION
2017**

RESEARCH PROJECTS 2017

• NATIONAL/ INTERNATIONAL PROJECTS 2017			
Contract No.	Project name	Manager	Beneficiary
„NUCLEU”			
PN 16 21 01 01	Research on the development of new mechatronic multiparameter systems for the control and balancing of disk type dynamic parts.	Cioboata Doina	MCI
PN 16 21 01 02	Development and implementation of measurement and control algorithms for smart systems for warning and mitigating the effects of natural or anthropic disasters.	Margaritescu Mihai	MCI
PN 16 21 01 03	Developing a system for functional analysis of the dynamic gear transmissions using advanced measurement and analysis techniques.	Logofatu Cristian	MCI
PN 16 21 01 04	Specialized of devices for determining physical parameters of water quality.	Dumitru Vlad	MCI
PN 16 21 01 05	New, competitive solutions in the development of complex mechatronic systems for controlling the operating parameters of gear pumps.	Vasile Iulian	MCI
PN 16 21 01 06	Study and analysis of the security solutions for the implementation and integration of industrial robots on production lines.	Spirescu Mugur	MCI
PN 16 21 01 07	Realization of an automated pneumo-electronic system for checking the tightness of cast parts with complex shapes from the machinery industry.	Badea Sorin	MCI
PN 16 21 01 08	Theoretical considerations and trends in design and metrological control of fluid flow measuring devices.	Darie Codrut	MCI
PN 16 21 01 09	Research on the development of new automated elements with transducers embedded in the construction of dimensional control devices and installations.	Georgescu V.	MCI
PN 16 21 01 10	Hall sensor based measuring device for fluids.	Bajenaru Valentina	MCI

PN 16 21 02 01	Research on the design and development of virtual and physical mechatronic and adaptronic and cyber-mechatronic and cyber-adaptronic laboratory and industrial devices.	Gheorghe I. Gheorghe	MCI
PN 16 21 04 01	Micro- / nanoscale coatings for improving the functional characteristics of structures mechatronic components.	Badita Liliana	MCI
PN 16 21 04 02	Enhancing the research capacity of INCDMTM in the field of smart laser measuring and strengthening the European Research Area connection.	Popan Gheorghe	MCI
PN 16 21 05 01	Advanced research on the use and optimization of selective laser sintering methods applicable in human hard tissue prosthesis and expansion in biomechatronics.	Pacioga Adrian	MCI
PN 16 21 06 01	Benchmarking study on the exploitation of research results of INCDMTM among the economic agents in the field of mechatronics.	Badea Diana	MCI
PN 16 21 06 02	Research on the development of an integrated management system to ensure the transition from ISO 9001: 2008 and ISO 14001: 2004 to ISO 9001: 2015 and ISO 14001: 2015 in the area of research - development.	Finat Carmen	MCI

SECTORAL PLAN PROGRAMME

8PS	Advanced methods for monitoring and increasing performance in your research career	Gheorghe I. Gheorghe	UPB
-----	--	----------------------	-----

PROGRAMME: "PARTNERSHIP IN PRIORITY AREAS"

179	Irrigation technology with rainwater collectors for individual vines in the early years of vegetation	Palade Doru Dumitru	UEFISCDI
268	Innovative mechatronic control system for the control of bearing rings on CNC machines as a factor in optimizing the quality	Cioboată Daniela	UEFISCDI
221	Ligament reconstruction using advanced structured materials based on natural and synthetic polymers	Comşa Stanca	UMF Carol Davila
224	Model experimental for detection and diagnosis of changes in vibratory processes using advanced	Cioboată Daniela	„Dunarea de Jos”

	techniques of model-based measurement and analysis		University
249	Electro-dynamic and electromagnetic actuators processed with LIGA technology	Sergiu Dumitru	UPB
250	Mechatronic system for measuring wheel profiles of railway vehicles in order to optimize reshaping on CNC machine tools and increase traffic safety	Savu Lucian	UPB-CNC PST OPTIMUM
279	Kelvin probe with Harmonic Potential for Space Applications	Mărgăritescu Mihai	Space Sciences Institute
159 CERMISO	Research Center for Intelligent Mechatronic Systems Used for Securing Objectives and Intervention	Popan George	MCI
85 KT AUTO COMP	Knowledge Transfer Partnerships to Increase Competitiveness of the Automotive and Parts Industry and Enhance Traffic Safety - KTAutoComp	Cioboată Daniela	MCI
117 CI	Smart high-precision mechatronic system for measuring linear microdisplacements in industrial and laboratory environments	Gheorghe I. Gheorghe	UEFISCDI
25 CI	Elaboration and characterization of new recipes of advanced materials from sintered metallic powders for special uses	Zapciu Aurel	UEFISCDI
79PED	Technology for monitoring the microbiological parameters of drinking water, destined for water quality management at national level	Paul-Nicolae Ancuta	UEFISCDI
211PED	Smart mechatronic system designed to ensure human security while securing objectives and interventions in areas of risk	Popan George	UEFISCDI
50 PED	Extensive hexapodal robot system for intelligent drive in limited or medium spaces	Mihai Margaritescu	UEFISCDI
128 STAR ROSA	Improved air distribution in astronaut cabins on the international space station and in other living spaces in remote space	Popan George	UTCB
138 STAR ROSA	Evaluation of 3D printing technology for the production of turbo pump wheels	Stanca Comsa	COMOTI

PART. - PN II - STAR

8	Sub-systems for nano-satellites	Popan Gh.	Institute of Space Science / INCDFLPR – STAR subsidiary
SCIENTIFIC EVENTS			
12M	International Conference of MECHATRONICS & CYBER-MIXMECHATRONICS «ICOME CYME'17	Gh Ion Gheorghe	MCI

PAPERS PUBLISHED IN MAGAZINES / SCIENTIFIC JOURNALS IN 2017

Gh. Ion Gheorghe, „Sisteme și Ecosisteme Mecatronice Inteligente și Cyber-Mix-Mecatronice Concepute prin Infrastructura de Cercetare «ECOSIN-MECATRON», destinate pentru Transferul Tehnologic în Industrie, Economie și Societate”, Conferinta Nationala - HERVEX, Baile Govora, Romania, 8-10.11.2017;

Gh. Ion Gheorghe, ”Inovarea în Clusterul Strategic Inovativ «MECHATREC» – Vector de creștere a valorii adăugate”, Panel: Innovation for Development and Competitiveness trough Clusters la The 9th Forum for Innovation Bucharest, October, 26-27, 2017;

Gh. Ion Gheorghe, ”Noi Ecosisteme Inteligente Mecatronice și Cyber-Mix-Mecatronice pentru Transferul Rezultatelor către Mediul Industrial, Economic și Societal, prin I.C. ECOSIN-MECATRON”, Panel: Cooperation to transform knowledge into marketable products and services, la The 9th Forum for Innovation Bucharest, October, 26-27, 2017;

Ilie Iulian si Gh. I. Gheorghe, ”Microsistem mecatronic inteligent în 4D pentru măsurări și poziționări de laborator și industriale”, Simpozionul cercetărilor doctorale de la ICSTM, Univ.Valahia Targoviste, 14.10.2017;

Anghel Constantin si Gh. I. Gheorghe, ”Aspecte tribologice ale mersului uman, considerații privind determinarea coeficientului de frecare prin analiza forțelor de reacțiune la sol”, Symposium of doctoral research - ICSTM, Univ.Valahia Targoviste, 14.10.2017;

Dorin Angelescu si Gh. I. Gheorghe, ”Studiu privind utilizarea senzorilor, actuatorilor si algoritmilor de comanda si control folositi in constructia robotilor mecatronici”, Symposium of doctoral research - ICSTM, Univ.Valahia Targoviste, 14.10.2017;

Gornoava Valentin si Gh. I. Gheorghe, ”Imbunatașirea caracteristicilor structurale ale componentelor mecatronice biomedicale”, Symposium of doctoral research -ICSTM, Univ.Valahia Targoviste, 14.10.2017;

Stanciu Danut, Gh. I. Gheorghe si Daniela Cioboata, ”Metode de prelucrare a datelor culese în cadrul măsurării dimensionale a elementelor de mecanică fină prin folosirea analizei armonice”, Symposium of doctoral research - ICSTM, Univ.Valahia Targoviste, 14.10.2017;

Gh. Ion Gheorghe, ”Sisteme și Ecosisteme Inteligente Mecatronice și Cyber-Mixmecatronice Dezvoltate în Infrastructura de Cercetare ”ECOSIN - MECATRON”, ASTR Days -ZASTR 2017, 6 - 7 Octombrie 2017, Constanța, Romania;

Stanca COMȘA, Florin Liviu ISVORANU, ”Types of nanopowders used in the quick making of mechanical parts based on selective laser sintering”, International Journal of Mechatronics and Applied Mechanics, 2017, Issue 1, indexed in Scopus, EBSCO and ProQuest;

Anghel Constantin, Gheorghe I. Gheorghe, ”TRIBOLOGICAL ASPECTS OF THE WALKING AND PRACTICAL DETERMINATION OF THE FRICTION COEFFICIENT USING A PORTABLE APPARATUS FOR GROUND REACTION FORCE ANALYSIS”, International Journal of Mechatronics and Applied Mechanics, 2017, Issue 1, indexed in Scopus, EBSCO and ProQuest;

Ștefan-Cătălin Popescu, Gheorghe I. Gheorghe, Octavian Donțu, ”RESEARCH ON IMPLEMENTATION

ORTHOPEDIC PROSTHESES ANKLE BY THE PROCESS RAPID PROTOTYPING”, International Journal of Mechatronics and Applied Mechanics, 2017, Issue 1, indexed in Scopus, EBSCO and ProQuest;

Ștefan-Cătălin Popescu, Gheorghe I. Gheorghe, Octavian Donțu, Besnea Daniel, ”SOME PROBLEMS BIOCOMPATIBLE MATERIALS USED FOR MAKING ENDOPROSTHESES ANKLE”, International Journal of Mechatronics and Applied Mechanics, 2017, Issue 1, indexed in Scopus, EBSCO and ProQuest;

Mihai Mărgăritescu, Ana Maria Eulampia Rolea, Anghel Constantin, ”REDUCING THE EFFECTS OF FLOODING USING LOCAL INTELLIGENT SYSTEMS”, International Journal of Mechatronics and Applied Mechanics, 2017, Issue 1, indexed in Scopus, EBSCO and ProQuest;

Dan N. Dumitriu, Mihai Mărgăritescu, Ana Maria Eulampia Rolea, ”DIRECT DYNAMICS OF GOUGH-STEWART HEXAPOD PLATFORMS USING THE REDUNDANT PARAMETERIZATION OF ROTATIONS BY FULL ROTATION MATRICES”, International Journal of Mechatronics and Applied Mechanics, 2017, Issue 1, indexed in Scopus, EBSCO and ProQuest;

Anca Atanasescu, Paul Nicolae Ancuța, Sorin Sorea, ”CONCEPTUAL MODEL OF COMPUTERIZED NATIONWIDE SCALE MULTIPARAMETER MONITORING SYSTEM FOR DRINKING WATER QUALITY”, International Journal of Mechatronics and Applied Mechanics, 2017, Issue 1, indexed in Scopus, EBSCO and ProQuest;

Mugur Spirescu, Sergiu Dumitru, Alexandru Constantinesu, Cristian Badea, ”HUMAN – ROBOTS SAFE COOPERATION IN AN INTEGRATED APPROACH”, International Journal of Mechatronics and Applied Mechanics, 2017, Issue 2, indexed in Scopus, EBSCO and ProQuest;

Stanca Comsa, Theodor Cezar Milian, Doina Gheorghiu, ”THE INFLUENCE OF EXPOSURE PARAMETERS ON THE QUALITY OF THE PARTS BUILT BY SELECTIVE LASER PROTOTYPING”, International Journal of Mechatronics and Applied Mechanics, 2017, Issue 2, indexed in Scopus, EBSCO and ProQuest;

Gheorghe I. Gheorghe, Iulian Ilie, ”RESEARCH WORK CONCERNING THE CONCEPTION AND IMPLEMENTATION OF MECHATRONIC AND ADAPTRONIC AND CYBER-MECATRONIC AND CYBER-ADAPTRONIC VIRTUAL AND PHYSICAL MODELS”, International Journal of Mechatronics and Applied Mechanics, 2017, Issue 2, indexed in Scopus, EBSCO and ProQuest;

Gheorghe I. Gheorghe, Iulian Ilie, ”STRUCTURAL AND MODULAR ARCHITECTURES FOR THE DESIGN OF SMART MECHATRONIC AND CYBER-MIXMECHATRONIC SYSTEMS USED IN LABORATORIES AND IN THE INDUSTRY”, International Journal of Mechatronics and Applied Mechanics, 2017, Issue 2, indexed in Scopus, EBSCO and ProQuest;

Anghel Constantin si Gh. Ion Gheorghe, „Study of piezoresistive and capacitive tactile sensors modeling and simulation for the best linearity with applications in modern microelectronics and walking analysis”, Journal of Engineering Sciences and Innovation, Vol. 2/2017 and Proceedings of the IEEE Explore, pp.183-186, factor impact: 9,237;

Gh. Ion Gheorghe, ”Studiu privind ”Clatronica” – ca materie programabilă pentru o ramură nouă a tehnologiei de viitor”, Revista Technomarket, Nr. 3/2017

Besnea Daniel, Dontu Octavian, Gheorghe I. Gheorghe, Victor Constantin, Spanu Alina, ”Mechatronic System for Solar Energy Acquisition”, International Conference of Mechatronics and Cyber-MixMechatronics - ICOMECYME, 7-8 sept. 2017, Bucharest, Romania, indexed in Springer Nature;

Gheorghe Gheorghe, Constantin Anghel, and Ilie Iulian, "Original and Scientific Contributions to Cyber-Mechatronics Systems Development for Industrial, Economical and Societal Environments", DOI: 10.7763/IJMO.2017.V7.590, International Journal of Modeling and Optimization, Vol. 7, No. 4, August 2017;

Liliana-Laura Badita, Gh. I. Gheorghe, Vasile Bratu, Valentin Gornoava, Marian Vocurek, Aurel Zapciu, Iulian Sorin Munteanu, "Mechanical Characterization of Nanostructured Thin Films Used to Improve Mechatronic Components", Scientific Bulletin of Valahia University - Materials and Mechanics, Volume 15, Issue 12 (Apr 2017) indexat in De Gruyter;

Angelescu Dorin, Gheorghe I. Gheorghe „Sistem integronic inteligent video-laser pentru măsurarea distanței și vitezei corpurilor aflate la distanțe mari”, A XI-editie a Simpozionului științific: Progresul Tehnologic - Rezultat al Cercetării, 27 aprilie 2017, Bucharest;

Anghel Constantin, Gheorghe I. Gheorghe, "Cercetari privind dezvoltarea sistemelor complexe cyber mecatronice pentru masurarea si prelucrarea informatizata a doua variabile ale unui proces tehnologic cu aplicatii in analiza mersului", A XI-editie a Simpozionului științific: Progresul Tehnologic - Rezultat al Cercetării, 27 aprilie 2017, Bucharest;

Ilie Iulian, Gheorghe I. Gheorghe, "Analiza privind utilizarea noilor tehnologii Si echipamente inteligente pentru monitorizarea si testarea solului si terenului arabil în scopul îmbunatatirii randamentului agricol", A XI-editie a Simpozionului științific: Progresul Tehnologic - Rezultat al Cercetării, 27 aprilie 2017, Bucharest;

Gheorghe I. GHEORGHE, "Subsisteme inteligente de securitate ale transferului de informații în cadrul sistemelor cybermechatronice și cyberadaptative", Revista Technomarket, Nr.2/2017;

Liliana Badita, Gheorghe I. GHEORGHE, Valentin Gornoava, Marian Vocurek, Aurel Zapciu, Iulian Munteanu, Vasile Bratu, "Mechanical Characterization of nanostructured thin films used to improve mechatronic components", The Scientific Bulletin of VALAHIA University MATERIALS and MECHANICS, Vol. 15, No.12/2017;

Gheorghe I. GHEORGHE, „Contribuții originale și științifice la dezvoltarea sistemelor cyber – mecatronice pentru medii industriale, economice și societale”, Revista Technomarket, Nr. 1/2017, ian. 2017;

Dumitru Sergiu, Comeaga Daniel, Anghel Constantin, Morega Alexandru Mihail, " MODELLING AND SIMULATION OF MEMS ELECTROMAGNETIC SCANNER CONTROL", International Conference on Mechanical, System and Control Engineering - ICMSC 2017 , Rusia, St. Petersburg , 19-21 Mai IEEE Xplore and Ei Compendex, ISI IEEE Xplore;

Angelescu Dorin, Gheorghe Gheorghe, "SISTEM INTEGRONIC INTELIGENT VIDEO-LASER PENTRU MASURAREA DISTANTEI SI VITEZEI CORPURILOR AFLATE LA DISTANTE MARI", Simpozionul National: Progresul Tehnologic – Rezultat al Cercetării, AGIR, 27 aprilie 2017;

Lucian Capitanu, Liliana-Laura Badita, Constantin Tiganesteanu, Virgil Florescu, "FRICTION AND CONTACT STRESS ANALYSIS DURING THE FRETTING FATIGUE", Simpozionul Anual al Institutului National de Mecanica Solidului al Academiei Romane - SISOM 2017, Bucharest, Romania, 18-19 Mai 2017;

Liliana-Laura Badita, Gheorghe Gheorghe, Adrian Marian Vocurek, Aurel Zapciu Iulian-Sorin Munteanu, Valentin Gornoava, "NANOMETRIC COATING TO IMPROVE THE FUNCTIONAL CHARACTERISTICS OF THE MECHATRONIC COMPONENTS AFFERENT TO INTELLIGENT MECHATRONIC SYSTEMS", A XV- a editie a Seminarului National de Nanostiinta si Nanotehnologie - Bucharest, Romania, 6 Iunie 2017;

Radulescu V., Dumitru S., "ENERGY MARKET AND THE PERMANENT MANAGEMENT, A POSSIBLE SOLUTION FOR SMALL HYDRO-POWER PLANTS, The 23 th Conference of Energy Engineering - CIE 2017, ORADEA, 08 - 09 June 2017;

Lucian Capitanu, Virgil Florescu, Liliana-Laura Badita, "DAMAGE ESTIMATOR, A POSSIBLE WAY TO PREDICT THE FAILURE OF HIP AND KNEE ENDOPROSTHESIS", Industrial Lubrication and Tribology, vol. 69, issue 1, pp. 71-80 (2017);

Adrian Pacioga, Corneliu Ronescu, Comsa Stanca, Gabriel Iacobescu, "Optimization of the constructive form of a Ti-6Al-4V acetabular prosthesis", U.P.B. Sci. Bull., ISSN: 1223-7027, BDI

Liliana-Laura Badita, Lucian Capitanu, Virgil Florescu, "STABILITY LOSS OF THE CEMENTED STEM OF HIP PROSTHESIS DUE TO FRETTING CORROSION FATIGUE", The 15 th International Conference on Tribology - SERBIATRIB 2017, Kragujevac, Serbia, 17 – 19 Mai 2017;

G. Constantin –UPB, I. Ghionea –UPB, A. Ghionea –UPB, D. Cioboata-INCDMTM, C.F. Bîtu –UPB, "INTEGRATION OF CAD-RBS-FEM TECHNIQUES IN REFABRICATION OF A LATHE USED FOR PROFILING WHEELSET", The 9 th International Working Conference - „Total Quality Management – Advanced and Intelligent Approaches", Belgrade, Serbia, 5-7 iunie 2017/ International Journal of Advanced Quality, Vol. 45, No. 2, 2017, ISSN: 2217-8155 , Editor: UASQ - United Association of Serbia for Quality

Daniel Besnea –UPB, Victor Constantin- UPB, Octavian Dontu, Alina Spanu, Doina Cioboata – INCDMTM, "ADDITIV MANUFACTURING CONCEPTS AND DESIGN FOR ADVANCED COMPOSITES MATERIALS", International Conference on Aerospace, Robotics, Manufacturing Systems, Mechanical Engineering, Mechatronics, Bioengineering and Neurorehabilitation - OPTIROB 2017, June 29 - July 3, 2017, JUPITER Tismana Hotel, Romania / International Journal of Modeling and Optimization (IJMO)

Daniela Cioboata, Aurel Abalaru, Danut Stanciu, Logofatu Cristian, "ADVANCED MEASUREMENT SYSTEMS FOR VIBRATION SIGNALS", The 5 th International Symposium On Electrical and Electronics Engineering – Galati, Romania, 20 - 22 October 2017, Proceeding of the ISEE 2017

Gheorghe Gheorghe, Iulian Ilie, Anghel Constantin, "ORIGINAL AND SCIENTIFIC CONTRIBUTIONS TO CYBER – MECHATRONICS SYSTEMS DEVELOPMENT FOR INDUSTRIAL, ECONOMICAL AND SOCIETAL ENVIRONMENTS", Doi: 0.7763/IJMO.2017.V7.590, International Journal of Modeling and Optimization (IJMO) , Vol. 7, No. 4, August 2017;

TECHNICAL BOOKS - 2017

- 1 **Book "Ingineria Cyber-Mecatronică și Clatronică", ISBN: 978-606-8261-26-3, 2017, CEFIN Publishing House**

SCIENTIFIC JOURNALS - 2017

1	International Journal of Mechatronics and Applied Mechanics, 2017, Issue 1, CEFIN Publishing House
2	International Journal of Mechatronics and Applied Mechanics, 2017, Issue 2, CEFIN Publishing House

GRANTED PATENTS - 2017

No.	INVENTION	INVENTOR
A / 128084/ 29.11. 2017	ANATOMIC – ADAPTIVE FEMORAL ROD	Stanca Comsa, Adrian Pacioga, Dan Ciobota, Stefan Maria, Florica Moldoveanu
129155/ 30.08.2017	GRIPPING DEVICE	Vasile Iulian
129520/ 29.09.2017	ANATOMO-ADAPTIVE IMPLANT FOR TREATMENT OF PROXIMAL CONGENITAL RADIO-ULNARY SYNTHESIS	Burnei Gheorghe, Comsa Stanca, Pacioga Adrian
129503/ 29.09.2017	TIPODONT DEVICE FOR SIMULATION OF STOMATOLOGICAL AND ORTHODONTIC TREATMENTS	Stanca Comsa, Adrian Pacioga, Maria Stefan, Dan Nastase Ciobota, Ion Mihail Stanciu Matei Stefan
Under issuance, cf. OSIM Decision nr.4/129/30.05.2017	EXTERNAL DIAMETER MONITORING MODULE USED DURING THE RECTIFICATION PROCESS	Aurel Ionel Abalaru, Danut Iulian Stanciu, Daniela Doina Cioboata, Cristian C-tin Logofatu, Florin Traistaru
Under issuance, cf. OSIM Decision nr.4/187/28.07.2017	DEVICE FOR MEASURING OPEN CIRCULAR PROFILES	Aurel Ionel Abalaru, Daniela Doina Cioboata, Danut Iulian Stanciu, Cristian C-tin Logofatu, Florin Traistaru

INVENTIONS WITH AWARDS - 2017

No	NAME OF SCIENTIFIC EVENTS	AWARD	NAME OF THE INVENTION WHICH WAS AWARDED THE PRIZE	INVENTORS
1.	PRO INVENT International Exhibition of Inventions 15th Edition 23 - 25 MARCH 2017 CLUJ - NAPOCA ROMANIA	DIPOMA OF EXCELLENCE AND GOLD MEDAL	MULTIPLE HEAD FOR MEASURING GEAR TEETH	Hacman Mihai Ionita Gheorghe

2.	PRO INVENT International Exhibition of Inventions 15th Edition 23 - 25 MARCH 2017 CLUJ - NAPOCA ROMANIA	DIPOMA OF EXCELLENCE AND GOLD MEDAL	AXIAL SYSTEM OF COUPLING - DISSENGAGING AND ANGULAR ORIENTATION	Gheorghe Gheorghe Moldovanu Alexandru Stoica Gheorghe
3.	The 45th International Exhibition of Inventions, Techniques and New Products 2017 GENEVA - SWITZERLAND	SILVER MEDAL	MULTIPLE HEAD FOR MEASURING GEAR TEETH	Hacman Mihai Ionita Gheorghe
4.	INNOVA International Exhibition of Inventions Second Edition MAY 2017 BARCELONA - SPAIN	GOLD MEDAL	MECHATRONIC FLEXIBLE MICROPOSITIONING EQUIPMENT WITH GRIPPER	Iulian Sorin Munteanu Gheorghe Gheorghe Aurel Zapciu Istriteanu Simona Elena Ancuta Paul
5.	INNOVA International Exhibition of Inventions Second Edition MAY 2017 BARCELONA - SPAIN	GOLD MEDAL	AXIAL SYSTEM OF COUPLING - DISSENGAGING AND ANGULAR ORIENTATION	Gheorghe Gheorghe Moldovanu Alexandru Stoica Gheorghe
6.	INNOVA International Exhibition of Inventions Second Edition MAY 2017 BARCELONA - SPAIN	AWARD OFFERED BY THE REPUBLIC OF CROATIA	MECHATRONIC FLEXIBLE MICROPOSITIONING EQUIPMENT WITH GRIPPER	Iulian Sorin Munteanu Gheorghe Gheorghe Aurel Zapciu Istriteanu Simona Elena Ancuta Paul
7.	International Exhibition of Inventions and Innovations "TRAIAN VUIA" 3rd Edition, 7-9 JUNE 2017 TIMISOARA, ROMANIA	GOLD MEDAL	MULTIPLE HEAD FOR MEASURING GEAR TEETH	Hacman Mihai Ionita Gheorghe
8.	International Exhibition of Inventions and Innovations "TRAIAN VUIA" 3rd Edition, 7-9 JUNE 2017 TIMISOARA, ROMANIA	GOLD MEDAL	MECHATRONIC FLEXIBLE MICROPOSITIONING EQUIPMENT WITH GRIPPER	Iulian Sorin Munteanu Gheorghe Gheorghe Aurel Zapciu Istriteanu Simona Elena Ancuta Paul
9.	International Exhibition of Inventions and Innovations "TRAIAN VUIA" 3rd Edition, 7-9 JUNE 2017 TIMISOARA, ROMANIA	GOLD MEDAL	SMART HIGH PRECISION MECHATRONIC SYSTEM FOR THE MEASUREMENT OF LINEAR MICRODISPLACEMENT S - DIGITRIL	Gheorghe Gheorghe Beca Paul; Olaru M. Mocanu Neculai Ancuta Paul Ilie Iulian Munteanu Iulian

10.	International Exhibition of Inventions and Innovations "TRAIAN VUIA" 3rd Edition, 7-9 JUNE 2017 TIMISOARA, ROMANIA	GOLD MEDAL	MULTIHEXAPODAL ROBOTIC POSITIONING SYSTEM	Margaritescu Mihai Brisan Cornel Panaitopol Horia
11.	International Exhibition of Inventions and Innovations "TRAIAN VUIA" 3rd Edition, 7-9 JUNE 2017 TIMISOARA, ROMANIA	SILVER MEDAL	PORTABLE ELECTRONIC EQUIPMENT AND METHOD FOR EVALUATION OF ENERGY CONSUMPTION DURING HUMAN WALKING	Capris Georgeta Miu Silvia Nicoleta Constantin Anghel Olaru Mircea Constantin Steluta
12.	International Exhibition of Inventions and Innovations "TRAIAN VUIA" 3rd Edition, 7-9 JUNE 2017 TIMISOARA, ROMANIA	SILVER MEDAL	CEMENTED ENDOPROSTHESES SURFACE PROCESSING FOR ENSURING IN-VIVO DURABILITY	Comsa Stanca Pacioga Adrian Bucur Doina Popescu Mihai
13.	International Exhibition of Inventions and Innovations "TRAIAN VUIA" 3rd Edition, 7-9 JUNE 2017 TIMISOARA, ROMANIA	SILVER MEDAL	INTERFACE CIRCUIT FOR TENSORIAL SENSORS	Anghel Constantin Dumitru Sergiu
14.	International Exhibition of Inventions and Innovations "TRAIAN VUIA" 3rd Edition, 7-9 JUNE 2017 TIMISOARA, ROMANIA	BRONZE MEDAL	AXIAL SYSTEM OF FAST COUPLING - DISSENGAGING	Gheorghe Gheorghe Moldovanu Alexandru Stoica Gheorghe
15.	International Exhibition of Inventions and Innovations "TRAIAN VUIA" 3rd Edition, 7-9 JUNE 2017 TIMISOARA, ROMANIA	BRONZE MEDAL	AXIAL SYSTEM OF COUPLING - DISSENGAGING AND ANGULAR ORIENTATION	Gheorghe Gheorghe Moldovanu Alexandru Stoica Gheorghe
16.	International Exhibition of Inventions and Innovations "TRAIAN VUIA" 3rd Edition, 7-9 JUNE 2017 TIMISOARA, ROMANIA	DIPOMA OF EXCELLENCE AND SPECIAL AWARD INMA Bucharest	SMART HIGH PRECISION MECHATRONIC SYSTEM FOR THE MEASUREMENT OF LINEAR MICRODISPLACEMENT S - DIGITRIL	Gheorghe Gheorghe Beca Paul; Olaru M. Mocanu Neculai Ancuta Paul Ilie Iulian Munteanu Iulian
17.	International Exhibition of Inventions and Innovations "TRAIAN VUIA" 3rd Edition, 7-9 JUNE 2017 TIMISOARA, ROMANIA	BRONZE MEDAL	ANTIEROUS MONITORING SYSTEM FOR MANUFACTURING LINES	Sergiu Dumitru Badea Cristian Radu

18.	International Exhibition of Inventions and Innovations "TRAIAN VUIA" 3rd Edition, 7-9 JUNE 2017 TIMISOARA, ROMANIA	DIPOMA OF EXCELLENCE by „Justin Capra” Association	SMART HIGH PRECISION MECHATRONIC SYSTEM FOR THE MEASUREMENT OF LINEAR MICRODISPLACEMENT S - DIGITRIL	Gheorghe Gheorghe Beca Paul; Olaru M. Mocanu Neculai Ancuta Paul Ilie Iulian Munteanu Iulian
19.	International Exhibition of Inventions and Innovations "TRAIAN VUIA" 3rd Edition, 7-9 JUNE 2017 TIMISOARA, ROMANIA	AWARD BY University «Politehnica» of Bucharest	SMART HIGH PRECISION MECHATRONIC SYSTEM FOR THE MEASUREMENT OF LINEAR MICRODISPLACEMENT S - DIGITRIL	Gheorghe Gheorghe Beca Paul; Olaru M. Mocanu Neculai Ancuta Paul Ilie Iulian Munteanu Iulian
20.	International Exhibition of Inventions and Innovations "TRAIAN VUIA" 3rd Edition, 7-9 JUNE 2017 TIMISOARA, ROMANIA	DIPOMA AND SPECIAL AWARD ISIM TIMISOARA	AXIAL SYSTEM OF FAST COUPLING - DISSENGAGING	Gheorghe Gheorghe Moldovanu Alexandru Stoica Gheorghe
21.	International Exhibition of Inventions and Innovations "TRAIAN VUIA" 3rd Edition, 7-9 JUNE 2017 TIMISOARA, ROMANIA	AWARD OFFERED BY THE REPUBLIC OF CROATIA	INCDMTM (all inventions presented on occasion of the Exhibition)	Authors of all inventions presented by INCDMTM



**INTERNATIONAL
SCIENTIFIC
PROTOCOLS**

Continuation in

• 2017 •

**1. Scientific Protocol signed with
“The International Centre of Mechatronics in
Linz – AUSTRIA” & INCDMTM Bucharest,
Romania**

**2. Scientific Protocol signed with
“Texas Institute of Science (TxIS) – USA” &
INCDMTM Bucharest, Romania**

